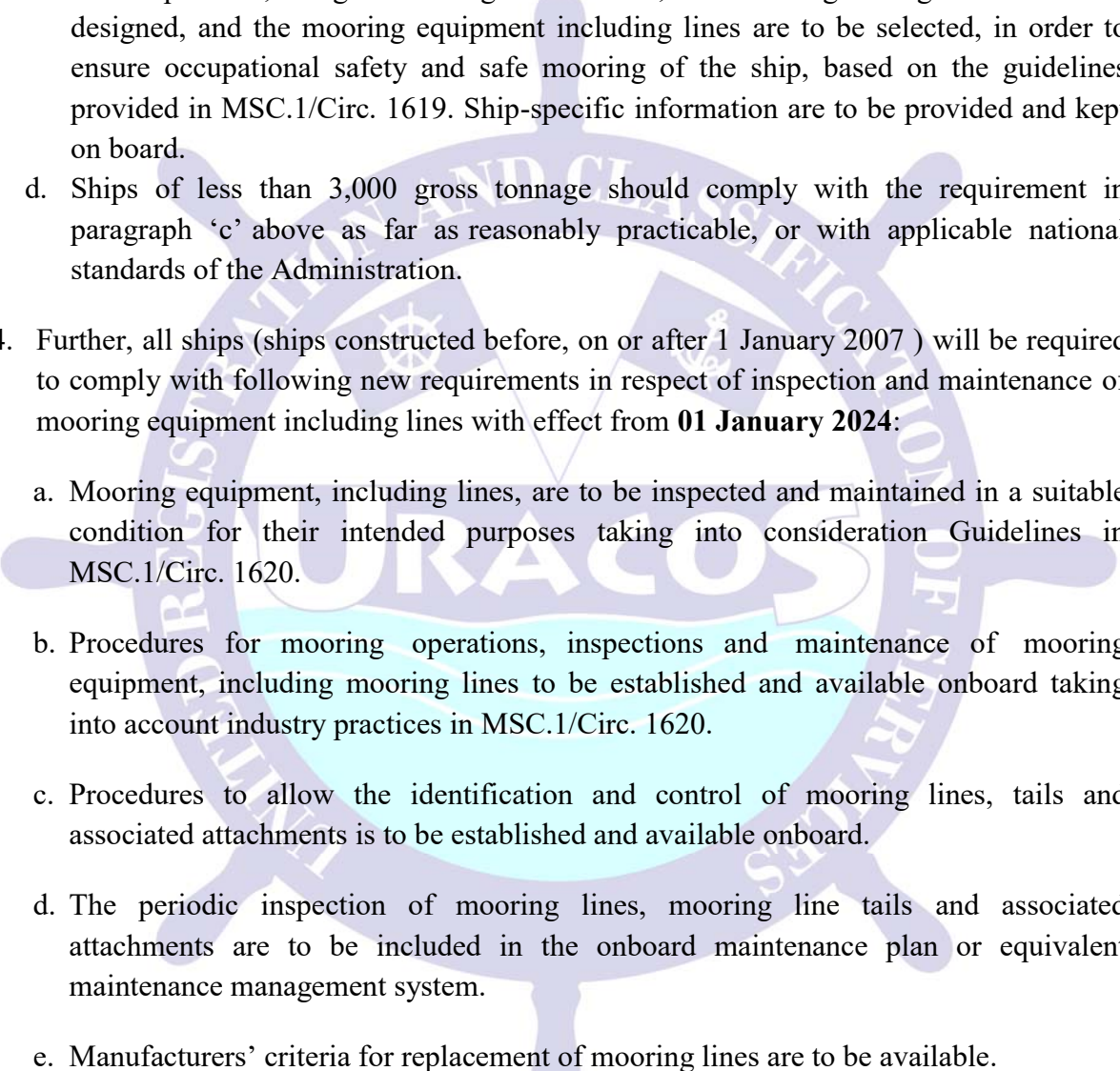

Subject: Amendments to SOLAS II-1, Reg.3-8 regarding New Requirements and Related Guidelines on Towing and Mooring Equipment.

1. IMO vide MSC. 474 (102) adopted amendments to SOLAS Ch.II-1, Reg. 3-8 which will come in to force from **1 January 2024**.
2. Applicability of revised SOLAS Ch.II-1, Reg. 3-8 is as follows:

Date of Construction	Requirements
Ships constructed on or after 1 January 2007	Existing requirements in paragraphs 4 to 6 of Regulation II-1/3-8
Ships for which: <ol style="list-style-type: none"> i. Building contract is placed on or after 1 January 2024; or ii. in the absence of a building contract, the keel of which is laid or which is at a similar stage of construction on or after 1 July 2024; or iii. the delivery of which is on or after 1 January 2027 	New requirements in paragraphs 7 and 8 of Regulation II-1/3-8
All SOLAS ships in operation, both existing (retroactive) and new, after 1 January 2024	New Requirements in paragraph 9 of Regulation II-1/3-8 (Maintenance and Inspection)
This regulation does not apply to towing arrangements provided in accordance with SOLAS II-1, Reg.3-4	

3. Accordingly, ships with building contract on or after 1 January 2024; or constructed on or after 1 July 2024; or delivered on or after 1 January 2027 will be required to comply with following new requirements:

- 
- a. Ship is to be provided with arrangements, equipment and fittings of sufficient safe working load to enable the safe conduct of all towing and mooring operations associated with the normal operation of the ship meeting the appropriate requirements in MSC.1/Circ. 1175/Rev.1 – Revised Guidance on Shipboard Towing and Mooring Equipment.
 - b. Each fitting or item of equipment provided under this regulation are to be clearly marked with any limitations associated with its safe operation, taking into account the strength of the supporting ship's structure and its attachment to it.
 - c. For ships of 3,000 gross tonnage and above, the mooring arrangement is to be designed, and the mooring equipment including lines are to be selected, in order to ensure occupational safety and safe mooring of the ship, based on the guidelines provided in MSC.1/Circ. 1619. Ship-specific information are to be provided and kept on board.
 - d. Ships of less than 3,000 gross tonnage should comply with the requirement in paragraph 'c' above as far as reasonably practicable, or with applicable national standards of the Administration.
4. Further, all ships (ships constructed before, on or after 1 January 2007) will be required to comply with following new requirements in respect of inspection and maintenance of mooring equipment including lines with effect from **01 January 2024**:
- a. Mooring equipment, including lines, are to be inspected and maintained in a suitable condition for their intended purposes taking into consideration Guidelines in MSC.1/Circ. 1620.
 - b. Procedures for mooring operations, inspections and maintenance of mooring equipment, including mooring lines to be established and available onboard taking into account industry practices in MSC.1/Circ. 1620.
 - c. Procedures to allow the identification and control of mooring lines, tails and associated attachments is to be established and available onboard.
 - d. The periodic inspection of mooring lines, mooring line tails and associated attachments are to be included in the onboard maintenance plan or equivalent maintenance management system.
 - e. Manufacturers' criteria for replacement of mooring lines are to be available.
 - f. Records of the original design concept, equipment, arrangement and specifications are to be available onboard.

Note: For ships the keels of which were laid before 1 January 2007 and without appropriate documentation, owners may establish the minimum breaking loads for

mooring based on the safe working load of mooring equipment provided onboard. If no safe working load is specified, then owners are advised to check strength of mooring equipment and their supporting hull structures based on MSC.1/Circ. 1175/Rev.1 and determine the minimum breaking loads based on the actual capacity of the equipment and their supporting hull structure on board. Manufacturer's test certificates for mooring lines, joining shackles and synthetic tails should be kept onboard and properly linked back to the equipment, if available.

- g. A document is to be provided on board for gathering the information above and describing how the information listed above is filed and collected.
 - h. Records of inspection and maintenance of mooring equipment and inspection and replacement of mooring lines should be kept updated and available on board.
5. Verification of compliance to above requirements will be undertaken at the initial survey for new ships and at the first periodical survey for the issuance of the Cargo Ship Safety Construction Certificate or renewal survey for the issuance of the Passenger Ship Safety Certificate on or after 1 January 2024 for existing ships.
6. Ship owners, managers, shipyards, ship designers and Masters are advised to be guided by above and consider these upcoming regulatory changes and guidelines when finalizing any new build designs. Further, ship owners and operators to ensure they have the required maintenance plans, procedures and records in place before these changes come into force.

Encl.:

- 1. IMO Res. MSC. 474 (102).
 - 2. MSC.1/Circ. 1619.
 - 3. MSC.1/Circ. 1620.
 - 4. MSC.1/Circ. 1175.
 - 5. MSC.1/Circ. 1175/Rev.1.
-

ANNEX 1

**RESOLUTION MSC.474(102)
(adopted on 11 November 2020)**

**AMENDMENTS TO THE INTERNATIONAL CONVENTION FOR THE SAFETY
OF LIFE AT SEA, 1974, AS AMENDED**

THE MARITIME SAFETY COMMITTEE,

RECALLING Article 28(b) of the Convention on the International Maritime Organization concerning the functions of the Committee,

RECALLING ALSO article VIII(b) of the International Convention for the Safety of Life at Sea, 1974 ("the Convention"), concerning the amendment procedure applicable to the annex to the Convention, other than to the provisions of chapter I,

HAVING CONSIDERED, at its 102nd session, amendments to the Convention proposed and circulated in accordance with article VIII(b)(i) of the Convention,

1 ADOPTS, in accordance with article VIII(b)(iv) of the Convention, amendments to the Convention the text of which is set out in the annex to the present resolution;

2 DETERMINES, in accordance with article VIII(b)(vi)(2)(bb) of the Convention, that the said amendments shall be deemed to have been accepted on 1 July 2023, unless, prior to that date, more than one third of the Contracting Governments to the Convention or Contracting Governments the combined merchant fleets of which constitute not less than 50% of the gross tonnage of the world's merchant fleet have notified the Secretary-General of their objections to the amendments;

3 INVITES Contracting Governments to the Convention to note that, in accordance with article VIII(b)(vii)(2) of the Convention, the amendments shall enter into force on 1 January 2024 upon their acceptance in accordance with paragraph 2 above;

4 REQUESTS the Secretary-General, for the purposes of article VIII(b)(v) of the Convention, to transmit certified copies of the present resolution and the text of the amendments contained in the annex to all Contracting Governments to the Convention;

5 REQUESTS ALSO the Secretary-General to transmit copies of this resolution and its annex to Members of the Organization which are not Contracting Governments to the Convention.

ANNEX

**AMENDMENTS TO THE INTERNATIONAL CONVENTION FOR
THE SAFETY OF LIFE AT SEA, 1974, AS AMENDED**

**CHAPTER II-1
CONSTRUCTION – STRUCTURE, SUBDIVISION AND STABILITY, MACHINERY
AND ELECTRICAL INSTALLATIONS**

**Part A
General**

Regulation 1 – Application

1 The existing paragraph 1.3 is replaced by the following:

"1.3 For the purpose of this chapter:

- .1 the expression *ships constructed* means ships the keels of which are laid or which are at a similar stage of construction;
- .2 the expression *ships constructed on or after 1 January 2024* means ships:
 - .1 for which the building contract is placed on or after 1 January 2024; or
 - .2 in the absence of a building contract, the keel of which is laid or which are at a similar stage of construction on or after 1 July 2024; or
 - .3 the delivery of which is on or after 1 January 2028.
- .3 the expression *all ships* means ships constructed before, on or after 1 January 2009;
- .4 a cargo ship, whenever built, which is converted to a passenger ship shall be treated as a passenger ship constructed on the date on which such a conversion commences."

**Part A-1
Structure of ships**

Regulation II-1/3-8 – Towing and mooring equipment

2 Regulation 3-8 is replaced by the following:

"1 Paragraphs 4 to 6 of this regulation apply to ships constructed on or after 1 January 2007.

2 Paragraphs 7 and 8 of this regulation only apply to ships:

- .1 for which the building contract is placed on or after 1 January 2024;
or

- .2 in the absence of a building contract, the keel of which is laid or which is at a similar stage of construction on or after 1 July 2024; or
- .3 the delivery of which is on or after 1 January 2027.

3 This regulation does not apply to towing arrangements provided in accordance with regulation 3-4.

4 Ships shall be provided with arrangements, equipment and fittings of sufficient safe working load to enable the safe conduct of all towing and mooring operations associated with the normal operation of the ship.

5 Arrangements, equipment and fittings provided in accordance with paragraph 4 above shall meet the appropriate requirements of the Administration or an organization recognized by the Administration under regulation I/6.*

* Refer to the *Guidance on shipboard towing and mooring equipment* (MSC.1/Circ.1175) for ships constructed on or after 1 January 2007 but before 1 January 2024 and the *Guidance on shipboard towing and mooring equipment* (MSC.1/Circ.1175/Rev.1) for ships constructed on or after 1 January 2024.

6 Each fitting or item of equipment provided under this regulation shall be clearly marked with any limitations associated with its safe operation, taking into account the strength of the supporting ship's structure and its attachment to it.

7 For ships of 3,000 gross tonnage and above, the mooring arrangement shall be designed, and the mooring equipment including lines shall be selected, in order to ensure occupational safety and safe mooring of the ship, based on the guidelines developed by the Organization.† Ship-specific information shall be provided and kept on board.‡

† Refer to the *Guidelines on the design of mooring arrangements and the selection of appropriate mooring equipment and fittings for safe mooring* (MSC.1/Circ.1619).

‡ Refer to towing and mooring arrangement plan in the *Guidelines on the design of mooring arrangements and the selection of appropriate mooring equipment and fittings for safe mooring* (MSC.1/Circ.1619).

8 Ships of less than 3,000 gross tonnage should comply with the requirement in paragraph 7 above as far as reasonably practicable, or with applicable national standards of the Administration.

9 For all ships, mooring equipment, including lines, shall be inspected and maintained in a suitable condition for their intended purposes.§

§ Refer to the *Guidelines for inspection and maintenance of mooring equipment including lines* (MSC.1/Circ.1620).

Part B-1 Stability

Regulation 7-2 – Calculation of the factor s_i

3 Paragraphs 5.2, 5.3 and 5.5 are replaced by the following:

"5.2 The factor s_i is to be taken as zero in those cases where the final waterline, taking into account sinkage, heel and trim, immerses:

- .1 for cargo ships, the lower edge of openings through which progressive flooding may take place and such flooding is not accounted for in the calculation of factor s_i . Such openings shall include air pipes, ventilators and openings which are closed by means of weathertight doors or hatch covers;
- .2 any part of the bulkhead deck in passenger ships considered a horizontal evacuation route for compliance with chapter II-2; and
- .3 for passenger ships subject to the provisions of regulation 1.1.1.1 and constructed before 1 January 2024, the lower edge of openings through which progressive flooding may take place and such flooding is not accounted for in the calculation of factor s_i . Such openings shall include air pipes, ventilators and openings which are closed by means of weathertight doors or hatch covers.

5.3 The factor s_i is to be taken as zero if, taking into account sinkage, heel and trim, any of the following occur in any intermediate stage or in the final stage of flooding:

- .1 immersion of any vertical escape hatch in the bulkhead deck of passenger ships and the freeboard deck of cargo ships intended for compliance with chapter II-2;
- .2 any controls intended for the operation of watertight doors, equalization devices, valves on piping or on ventilation ducts intended to maintain the integrity of watertight bulkheads from above the bulkhead deck of passenger ships and the freeboard deck of cargo ships become inaccessible or inoperable;
- .3 immersion of any part of piping or ventilation ducts located within the assumed extent of damage and carried through a watertight boundary if this can lead to the progressive flooding of compartments not assumed as flooded; and
- .4 for passenger ships constructed on or after 1 January 2024, immersion of the lower edge of openings through which progressive flooding may take place and such flooding is not accounted for in the calculation of factor s_i . Such openings shall include air pipes, ventilators and openings which are closed by means of weathertight doors or hatch covers.

5.5 Except as provided in paragraph 5.3.1, openings closed by means of watertight manhole covers and flush scuttles, remotely operated sliding watertight

doors, side scuttles of the non-opening type as well as watertight access doors and watertight hatch covers required to be kept closed during navigation in accordance with regulations 22 to 24 need not be considered."

Part B-2
Subdivision, watertight and weathertight integrity

Regulation 12 – Peak and machinery space bulkheads, shaft tunnels, etc.

4 At the beginning of paragraph 6.1, the text "For ships subject to the provisions of regulation 1.1.1.1 and constructed before 1 January 2024," is added; the word "Except" is replaced by "except"; and the reference to "paragraph 6.2" is replaced by "paragraph 6.3".

5 A new paragraph 6.2 is inserted after existing paragraph 6.1 and the subsequent paragraph is renumbered accordingly:

"6.2 For ships constructed on or after 1 January 2024, except as provided in paragraph 6.3, the collision bulkhead may be pierced below the bulkhead deck of passenger ships and the freeboard deck of cargo ships by not more than one pipe for dealing with fluid in the forepeak tank, provided that the pipe is fitted with a remotely controlled valve capable of being operated from above the bulkhead deck of passenger ships and the freeboard deck of cargo ships. The valve shall be normally closed. If the remote control system should fail during operation of the valve, the valve shall close automatically or be capable of being closed manually from a position above the bulkhead deck of passenger ships and the freeboard deck of cargo ships. The valve shall be located at the collision bulkhead on either the forward or aft side, provided the space on the aft side is not a cargo space. The valve shall be of steel, bronze or other approved ductile material. Valves of ordinary cast iron or similar material are not acceptable."

Regulation 13 – Openings in watertight bulkheads below the bulkhead deck in passenger ships

6 Regulation 13, including its title, is replaced by the following:

"Regulation 13 – Openings in watertight boundaries below the bulkhead deck in passenger ships

1 The number of openings in watertight boundaries shall be reduced to the minimum compatible with the design and proper working of the ship; satisfactory means shall be provided for closing these openings.

2.1 Where pipes, scuppers, electric cables, etc., are carried through watertight boundaries, arrangements shall be made to ensure the watertight integrity of the boundaries.

2.2 Valves not forming part of a piping system shall not be permitted in watertight boundaries.

2.3 Lead or other heat sensitive materials shall not be used in systems which penetrate watertight boundaries, where deterioration of such systems in the event of fire would impair the watertight integrity of the boundaries.

3 No doors, manholes or access openings are permitted in watertight transverse bulkheads dividing a cargo space from an adjoining cargo space, except as provided in paragraph 8.1 and in regulation 14.

4 Subject to paragraph 9, not more than one door, apart from the doors to shaft tunnels, may be fitted in each watertight bulkhead within spaces containing the main and auxiliary propulsion machinery including boilers serving the needs of propulsion. Where two or more shafts are fitted, the tunnels shall be connected by an intercommunicating passage. There shall be only one door between the machinery space and the tunnel spaces where two shafts are fitted and only two doors where there are more than two shafts. All these doors shall be of the sliding type and shall be so located as to have their sills as high as practicable. The hand gear for operating these doors from above the bulkhead deck shall be situated outside the spaces containing the machinery.

5.1 Watertight doors, except as provided in paragraph 8.1 or regulation 14, shall be power-operated sliding doors complying with the requirements of paragraph 6.

5.2 The means of operation whether by power or by hand of any power-operated sliding watertight door shall be capable of closing the door with the ship listed to 15° either way. Consideration shall also be given to the forces which may act on either side of the door as may be experienced when water is flowing through the opening applying a static head equivalent to a water height of at least 1 m above the sill on the centreline of the door.

5.3 Watertight door controls, including hydraulic piping and electric cables, shall be kept as close as practicable to the bulkhead in which the doors are fitted, in order to minimize the likelihood of them being involved in any damage which the ship may sustain. The positioning of watertight doors and their controls shall be such that if the ship sustains damage within one fifth of the breadth of the ship, as defined in regulation 2, such distance being measured at right angles to the centreline at the level of the deepest subdivision draught, the operation of the watertight doors clear of the damaged portion of the ship is not impaired.

6.1 Each power-operated sliding watertight door:

- .1 shall have a vertical or horizontal motion;
- .2 shall, subject to paragraph 9, be normally limited to a maximum clear opening width of 1.2 m. The Administration may permit larger doors only to the extent considered necessary for the effective operation of the ship provided that other safety measures, including the following, are taken into consideration:
 - .1 special consideration shall be given to the strength of the door and its closing appliances in order to prevent leakages; and
 - .2 the door shall be located inboard the damage zone $B/5$;
- .3 shall be fitted with the necessary equipment to open and close the door using electric power, hydraulic power or any other form of power that is acceptable to the Administration;
- .4 shall be provided with an individual hand-operated mechanism. It shall be possible to open and close the door by hand at the door itself from either side, and in addition, close the door from an

accessible position above the bulkhead deck with an all-round crank motion or some other movement providing the same degree of safety acceptable to the Administration. Direction of rotation or other movement is to be clearly indicated at all operating positions. The time necessary for the complete closure of the door, when operating by hand gear, shall not exceed 90 s with the ship in the upright position. Visual indicators to show whether the door is open or closed shall be provided at the accessible position above the bulkhead deck;

- .5 shall be provided with controls for opening and closing the door by power from both sides of the door and also for closing the door by power from the central operating console(s) required by paragraph 7.1;
- .6 shall be provided with an audible alarm, distinct from any other alarm in the area, which will sound whenever the door is closed remotely by power and which shall sound for at least 5 s but no more than 10 s before the door begins to move and shall continue sounding until the door is completely closed. In the case of remote hand operation it is sufficient for the audible alarm to sound only when the door is moving. Additionally, in passenger areas and areas of high ambient noise the Administration may require the audible alarm to be supplemented by an intermittent visual signal at the door; and
- .7 shall have an approximately uniform rate of closure under power. The closure time, from the time the door begins to move to the time it reaches the completely closed position, shall in no case be less than 20 s or more than 40 s with the ship in the upright position.

6.2 The electrical power required for power-operated sliding watertight doors shall be supplied from the emergency switchboard either directly or by a dedicated distribution board situated above the bulkhead deck. The associated control, indication and alarm circuits shall be supplied from the emergency switchboard either directly or by a dedicated distribution board situated above the bulkhead deck and be capable of being automatically supplied by the transitional source of emergency electrical power required by regulation 42.3.1.3 in the event of failure of either the main or emergency source of electrical power.

6.3 Power-operated sliding watertight doors shall have either:

- .1 a centralized hydraulic system with two independent power sources each consisting of a motor and pump capable of simultaneously closing all doors. In addition, there shall be for the whole installation hydraulic accumulators of sufficient capacity to operate all the doors at least three times, i.e. closed-open-closed, against an adverse list of 15°. This operating cycle shall be capable of being carried out when the accumulator is at the pump cut-in pressure. The fluid used shall be chosen considering the temperatures liable to be encountered by the installation during its service. The power-operating system shall be designed to minimize the possibility of having a single failure in the hydraulic piping adversely affect the operation of more than one door. The hydraulic system shall be provided with a low-level alarm for hydraulic fluid reservoirs serving

the power-operated system and a low gas pressure alarm or other effective means of monitoring loss of stored energy in hydraulic accumulators. These alarms are to be audible and visual and shall be situated on the central operating console(s) required by paragraph 7.1; or

- .2 an independent hydraulic system for each door with each power source consisting of a motor and pump capable of opening and closing the door. In addition, there shall be a hydraulic accumulator of sufficient capacity to operate the door at least three times, i.e. closed-open-closed, against an adverse list of 15°. This operating cycle shall be capable of being carried out when the accumulator is at the pump cut-in pressure. The fluid used shall be chosen considering the temperatures liable to be encountered by the installation during its service. A low gas pressure group alarm or other effective means of monitoring loss of stored energy in hydraulic accumulators shall be provided at the central operating console(s) required by paragraph 7.1. Loss of stored energy indication at each local operating position shall also be provided; or
- .3 an independent electrical system and motor for each door with each power source consisting of a motor capable of opening and closing the door. The power source shall be capable of being automatically supplied by the transitional source of emergency electrical power as required by regulation 42.4.2 - in the event of failure of either the main or emergency source of electrical power and with sufficient capacity to operate the door at least three times, i.e. closed-open-closed, against an adverse list of 15°.

For the systems specified in paragraphs 6.3.1, 6.3.2 and 6.3.3, provision should be made as follows: Power systems for power-operated sliding watertight doors shall be separate from any other power system. A single failure in the electric or hydraulic power-operated systems excluding the hydraulic actuator shall not prevent the hand operation of any door.

6.4 Control handles shall be provided at each side of the bulkhead at a minimum height of 1.6 m above the floor and shall be so arranged as to enable persons passing through the doorway to hold both handles in the open position without being able to set the power closing mechanism in operation accidentally. The direction of movement of the handles in opening and closing the door shall be in the direction of door movement and shall be clearly indicated.

6.5 As far as practicable, electrical equipment and components for watertight doors shall be situated above the bulkhead deck and outside hazardous areas and spaces.

6.6 The enclosures of electrical components necessarily situated below the bulkhead deck shall provide suitable protection against the ingress of water.*

* Refer to the following publication IEC 60529:2003:

- .1 electrical motors, associated circuits and control components; protected to IPX 7 standard;

- .2 door position indicators and associated circuit components; protected to IPX 8 standard; and
- .3 door movement warning signals; protected to IPX 6 standard.

Other arrangements for the enclosures of electrical components may be fitted provided the Administration is satisfied that an equivalent protection is achieved. The water pressure IPX 8 shall be based on the pressure that may occur at the location of the component during flooding for a period of 36 h.

6.7 Electric power, control, indication and alarm circuits shall be protected against fault in such a way that a failure in one door circuit will not cause a failure in any other door circuit. Short circuits or other faults in the alarm or indicator circuits of a door shall not result in a loss of power operation of that door. Arrangements shall be such that leakage of water into the electrical equipment located below the bulkhead deck will not cause the door to open.

6.8 A single electrical failure in the power operating or control system of a power-operated sliding watertight door shall not result in a closed door opening. Availability of the power supply should be continuously monitored at a point in the electrical circuit as near as practicable to each of the motors required by paragraph 6.3. Loss of any such power supply should activate an audible and visual alarm at the central operating console(s) required by paragraph 7.1.

7.1 A central operating console for all power-operated sliding watertight doors shall be located in the safety centre in accordance with regulation II-2/23. If the safety centre is located in a separate space adjacent to the navigation bridge, a central operating console shall also be located on the navigation bridge. The central operating console(s) shall have a "master mode" switch with two modes of control: a "local control" mode, which shall allow any door to be locally opened and locally closed after use without automatic closure, and a "doors closed" mode, which shall automatically close any door that is open in not more than 60 s with the ship in an upright position. The "doors closed" mode shall permit doors to be opened locally and shall automatically re-close the doors upon release of the local control mechanism. The "master mode" switch shall normally be in the "local control" mode. The "doors closed" mode shall only be used in an emergency or for testing purposes.

7.2 For ships subject to the provisions of regulation 1.1.1.1 and constructed before 1 January 2024, the central operating console at the navigation bridge shall be provided with a diagram showing the location of each door, with visual indicators to show whether each door is open or closed. A red light shall indicate a door is fully open and a green light shall indicate a door is fully closed. When the door is closed remotely the red light shall indicate the intermediate position by flashing. The indicating circuit shall be independent of the control circuit for each door.

7.3 For ships constructed on or after 1 January 2024, the central operating console(s) shall be provided with a diagram showing the location of each power-operated sliding watertight door, with visual indicators to show whether each door is open or closed. A red light shall indicate a door is fully open and a green light shall indicate a door is fully closed. When the door is closed remotely the red light shall indicate the intermediate position by flashing. The indicating circuit shall be independent of the control circuit for each door. Indication shall also be provided to the onboard stability computer, if installed in accordance with regulation II-1/8-1.3.1.

7.4 It shall not be possible to remotely open any door from the central operating console.

8.1 If the Administration is satisfied that such doors are essential, watertight doors of satisfactory construction may be fitted in watertight bulkheads dividing cargo spaces on 'tween decks. Such doors may be hinged, rolling or sliding doors but shall not be remotely controlled. They shall be fitted at the highest level and as far from the shell plating as practicable, but in no case shall the outboard vertical edges be situated at a distance from the shell plating which is less than one fifth of the breadth of the ship, as defined in regulation 2, such distance being measured at right angles to the centreline at the level of the deepest subdivision draught.

8.2 Should any such doors be accessible during the voyage, they shall be fitted with a device which prevents unauthorized opening. When it is proposed to fit such doors, the number and arrangements shall receive the special consideration of the Administration.

9 Portable plates on bulkheads shall not be permitted except in machinery spaces. The Administration may permit not more than one power-operated sliding watertight door larger than those specified in paragraph 6.1.2 to be substituted for these portable plates in each watertight bulkhead, provided these doors are intended to remain closed during navigation except in case of urgent necessity at the discretion of the master. These doors need not meet the requirements of paragraph 6.1.4 regarding complete closure by hand-operated gear in 90 s.

10.1 Where trunkways or tunnels for access from crew accommodation to the machinery spaces, for piping, or for any other purpose are carried through watertight bulkheads, they shall be watertight and in accordance with the requirements of regulation 16-1. The access to at least one end of each such tunnel or trunkway, if used as a passage at sea, shall be through a trunk extending watertight to a height sufficient to permit access above the bulkhead deck. The access to the other end of the trunkway or tunnel may be through a watertight door. Such trunkways or tunnels shall not extend through the first subdivision bulkhead abaft the collision bulkhead.

10.2 Where it is proposed to fit tunnels piercing watertight bulkheads, these shall receive the special consideration of the Administration.

10.3 Where trunkways in connection with refrigerated cargo and ventilation or forced draught trunks are carried through more than one watertight bulkhead, the means of closure at such openings shall be operated by power and be capable of being closed from a central position situated above the bulkhead deck."

Regulation 15 – Openings in the shell plating below the bulkhead deck of passenger ships and the freeboard deck of cargo ships

7 Paragraph 9 is replaced by the following:

"9 For ships subject to the provisions of regulation 1.1.1.1 and constructed before 1 January 2024, gangway, cargo and fuelling ports fitted below the bulkhead deck of passenger ships and the freeboard deck of cargo ships shall be watertight and in no case be so fitted as to have their lowest point below the deepest subdivision draught."

8 The following new paragraph 10 is inserted after new paragraph 9 and existing paragraphs 10.1 and 10.2 are deleted.

"10 For ships constructed on or after 1 January 2024, cargo ports and other similar openings (e.g. gangway and fuelling ports) in the side of ships below the bulkhead deck of passenger ships and the freeboard deck of cargo ships shall be fitted with doors so designed as to ensure the same watertightness and structural integrity as the surrounding shell plating. Unless otherwise granted by the Administration, these openings shall open outwards. The number of such openings shall be the minimum compatible with the design and proper working of the ship. In no case shall these openings be so fitted as to have their lowest point below the deepest subdivision draught."

Regulation 16 – Construction and initial tests of watertight closures

9 Paragraph 1.1 is replaced by the following:

"1.1 The design, materials and construction of all watertight closures such as doors, hatches, sidescuttles, gangway and cargo ports, valves and pipes referred to in these regulations shall be to the satisfaction of the Administration."

Regulation 17 – Internal watertight integrity of passenger ships above the bulkhead deck

10 Paragraph 1 is replaced by the following:

"1 For passenger ships subject to the provisions of regulation 1.1.1.1 and constructed before 1 January 2024, the Administration may require that all reasonable and practicable measures shall be taken to limit the entry and spread of water above the bulkhead deck. Such measures may include partial bulkheads or webs. When partial watertight bulkheads and webs are fitted on the bulkhead deck, above or in the immediate vicinity of watertight bulkheads, they shall have watertight shell and bulkhead deck connections so as to restrict the flow of water along the deck when the ship is in a heeled damaged condition. Where the partial watertight bulkhead does not line up with the bulkhead below, the bulkhead deck between shall be made effectively watertight. Where openings, pipes, scuppers, electric cables, etc. are carried through the partial watertight bulkheads or decks within the immersed part of the bulkhead deck, arrangements shall be made to ensure the watertight integrity of the structure above the bulkhead deck.*"

* Refer to the *Guidance notes on the integrity of flooding boundaries above the bulkhead deck of passenger ships for proper application of regulations II-1/8 and 20, paragraph 1, of SOLAS 1974, as amended* (MSC/Circ.541, as may be amended).

11 The following new paragraphs 2 and 3 are inserted after new paragraph 1 and the subsequent paragraphs are renumbered accordingly:

"2 For ships constructed on or after 1 January 2024, the internal watertight subdivision arrangements to limit the entry and spread of water above the bulkhead deck shall be in accordance with the design arrangements necessary for compliance with the stability requirements in parts B-1, and B-2 if applicable. Where pipes, scuppers, electric cables, etc. are carried through internal watertight boundaries that are immersed at any intermediate or final stage of flooding in damage cases that contribute to the attained subdivision index *A*, arrangements shall be made to ensure their watertight integrity.

3 For ships constructed on or after 1 January 2024, doors in internal watertight subdivision arrangements above the bulkhead deck, and also above the worst intermediate or final stage of flooding waterlines, shall be capable of preventing the passage of water when immersed in the required range of positive stability for any damage cases contributing to the attained subdivision index *A*. These doors may remain open provided they can be remotely closed from the navigation bridge. They shall always be ready to be immediately closed."

Regulation 17-1 – Integrity of the hull and superstructure, damage prevention and control on ro-ro passenger ships

12 Paragraphs 1.1 to 1.3 are replaced by the following:

"1.1 All access from the ro-ro deck that leads to spaces below the bulkhead deck shall have a lowest point which is not less than 2.5 m above the bulkhead deck, unless the access is covered by the provisions of paragraphs 1.2 or 1.3.

1.2 Where vehicle ramps are installed to give access to spaces below the bulkhead deck, their openings shall be able to be closed weathertight to prevent ingress of water below and fitted with alarms and open/close indicators on the navigation bridge. The means of closure shall be watertight if the deck is intended as a watertight horizontal boundary under regulation 7-2.6.

1.3 Subject to regulations 23.3 and 23.6, the Administration may permit the fitting of particular accesses to spaces below the bulkhead deck provided they are necessary for the essential working of the ship, e.g. the movement of machinery and stores, and subject to such accesses being made watertight, fitted with alarms and open/close indicators on the navigation bridge."

Part B-4 Stability management

Regulation 19 – Damage control information*

* Refer to the *Guidelines for damage control plans and information to the master* (MSC.1/Circ.1245), as amended by MSC.1/Circ.1570 and to the *Guidelines for verification of damage stability requirements for tankers* (MSC.1/Circ.1461).

13 The following new paragraph 5 is inserted after existing paragraph 4:

"5 For passenger ships constructed on or after 1 January 2024, and to which regulation 8-1.3 applies, the damage control information shall include a reference to activation of damage stability support from the onboard stability computer, if installed, and to shore-based support when provided."

Regulation 21 – Periodical operation and inspection of watertight doors, etc., in passenger ships

14 Paragraph 1 is replaced by the following:

"1 Operational tests of watertight doors, sidescuttles, valves and closing mechanisms of scuppers shall take place weekly. In ships in which the voyage exceeds one week in duration, a complete set of operational tests shall be held before the voyage commences, and others thereafter at least once a week during the voyage."

Regulation 22 – Prevention and control of water ingress, etc.

15 In paragraphs 1 and 4, existing reference to "regulation 13.10" is replaced by the reference to "regulation 13.9".

16 Paragraphs 5 and 6 are replaced by the following:

"5 Watertight doors fitted in watertight bulkheads dividing cargo spaces on tween decks in accordance with regulation 13.8.1 shall be closed before the voyage commences and shall be kept closed during navigation. The time at which such doors are opened or closed shall be recorded in such logbook as may be prescribed by the Administration.

6 For ships subject to the provisions of regulation 1.1.1.1 and constructed before 1 January 2024, gangway, cargo and fuelling ports fitted below the bulkhead deck of passenger ships and the freeboard deck of cargo ships shall be effectively closed and secured watertight before the voyage commences, and shall be kept closed during navigation."

17 A new paragraph 7 is inserted after existing paragraph 6 and the subsequent paragraphs are renumbered accordingly:

"7 For ships constructed on or after 1 January 2024, gangway, cargo and fuelling ports fitted below the bulkhead deck of passenger ships and the freeboard deck of cargo ships and all watertight hatches shall be effectively closed and secured watertight before the voyage commences, and shall be kept closed during navigation. However, the master may permit a watertight hatch to be opened during navigation for a limited period of time sufficient to permit passage or for access. It shall then be closed."

18 In the renumbered paragraph 8.2, existing reference to "paragraph 7.1" is replaced by reference to "paragraph 8.1".

19 In the renumbered paragraph 8.4, existing text "paragraphs 7.1 to 7.3" is replaced by "paragraphs 8.1 to 8.3".

20 In the renumbered paragraph 10, existing text "paragraphs 7.1 and 7.4" is replaced by "paragraphs 8.1 and 8.4".

21 In the renumbered paragraph 11, existing reference to "paragraph 7" is replaced by reference to "paragraph 8".

22 In the renumbered paragraph 12, existing reference to "paragraph 12" is replaced by reference to "paragraph 13" and the existing reference to "paragraph 13" is replaced by reference to "paragraph 14".

23 Renumbered paragraph 14.2 is replaced by:

".2 For any ship that has one or more sidescuttles so placed that the requirements of paragraph 14 would apply when it was floating at its deepest subdivision draught, the Administration may indicate the limiting mean draught at which these sidescuttles will have their sills above the line drawn parallel to the bulkhead deck at side of passenger ships and the freeboard deck at side of cargo ships, and having its lowest point 1.4 m plus 2.5% of the breadth of the ship above the waterline corresponding to the limiting mean draught, and at which it will therefore be permissible for the voyage to commence without them being closed and locked and to be opened during navigation on the responsibility of the master. In tropical zones as defined in the International Convention on Load Lines, 1966 in force, this limiting draught may be increased by 0.3 m."

24 Renumbered paragraph 17 is deleted.

Regulation 23 – Special requirements for ro-ro passenger ships

25 In paragraph 5, existing reference to "regulation 22.12" is replaced by reference to "regulation 22.13".

Part D Electrical installations

Regulation 42 – Emergency source of electrical power in passenger ships

26 In paragraph 4.2, existing reference to "regulation 13.7.3.3" is replaced by reference to "regulation 13.6.3.3" and existing reference to "regulation 13.7.2" is replaced by reference to "regulation 13.6.2".

4 ALBERT EMBANKMENT
LONDON SE1 7SR
Telephone: +44 (0)20 7735 7611 Fax: +44 (0)20 7587 3210

MSC.1/Circ.1619*
11 December 2020

**GUIDELINES ON THE DESIGN OF MOORING ARRANGEMENTS
AND THE SELECTION OF APPROPRIATE MOORING EQUIPMENT
AND FITTINGS FOR SAFE MOORING**

1 The Maritime Safety Committee, at its 102nd session (4 to 11 November 2020), having considered a proposal by the Sub-Committee on Ship Design and Construction, at its sixth session (4 to 8 February 2019), and recognizing the importance of design of mooring arrangements and the selection of appropriate mooring equipment and fittings for safe mooring operations, with a view to ensuring a uniform approach towards the application of the provisions of SOLAS regulation II-1/3-8, as amended by resolution MSC.474(102), which is expected to become effective on 1 January 2024, approved the *Guidelines on the design of mooring arrangements and the selection of appropriate mooring equipment and fittings for safe mooring*, as set out in the annex.

2 Member States are invited to bring the annexed Guidelines to the attention of ship designers, shipyards, shipowners, ship managers, bareboat charterers and other organizations or persons responsible for design of mooring arrangements and the selection of appropriate mooring equipment and fittings.

3 Member States are also invited to bring the annexed Guidelines to the attention of shipmasters, ships' officers and crew, and all other parties concerned.

* Re-issued to refer to the correct resolution MSC.474(102) in paragraph 1 of the cover sheet.

ANNEX

GUIDELINES ON THE DESIGN OF MOORING ARRANGEMENTS AND THE SELECTION OF APPROPRIATE MOORING EQUIPMENT AND FITTINGS FOR SAFE MOORING

1 Introduction

1.1 Historical evolution in ship designs, especially the design of large ships, has resulted in optimized performance and a greater degree of complexity; this has not been extended to the design of ships' mooring arrangements. These Guidelines support the application of the provisions of SOLAS for mooring arrangements and encourage greater consideration of the occupational safety and safe mooring of the ship when designing new ships. Improving the design of mooring arrangements should enhance usability and safety during towing and mooring operations.

1.2 Regulations II-1/3-8.7 and II-1/3-8.8 of the International Convention for the Safety of Life at Sea (SOLAS), as amended, require that for ships of 3,000 gross tonnage and above constructed on or after 1 January 2024, the mooring arrangement shall be designed, and the mooring equipment including lines shall be selected, in order to ensure occupational safety and safe mooring of the ship; and ships of less than 3,000 gross tonnage constructed on or after 1 January 2024 should comply with these requirements as far as reasonably practicable, or with applicable national standards of the Administration.

1.3 These Guidelines provide an approach to the design of mooring arrangements, and the selection of mooring equipment and fittings, which should be applied in conjunction with principles of ergonomics and usability.

2 Definitions

For the purposes of these Guidelines:

2.1 *Line Design Break Force (LDBF)* means the minimum force that a new, dry, spliced, mooring line will break at. This is for all synthetic cordage materials.

2.2 *Mooring area* refers to the dedicated area on a ship where mooring equipment is installed and line-handling takes place. It also includes areas where there is a risk of personnel injury in event of snap-back or other failure of mooring equipment. There may be multiple mooring areas on a ship.

2.3 *Mooring arrangements* means the configuration of the mooring equipment and fittings and other design features of the ships related to the mooring operation, i.e. lighting and communication equipment.

2.4 *Mooring equipment and fittings* means items such as mooring winches, capstans, bollards, bits, fairleads, rollers, chocks, etc. and also includes mooring lines.

2.5 *Mooring lines* means ropes, wires and combinations used for mooring operations other than messenger lines but including tails.

2.6 *Mooring operations* means normal mooring and unmooring of the ship, including associated in-harbour towing movements.

2.7 *Mooring personnel* means personnel tasked to assist in the activity of mooring and unmooring ships, either ashore or from mooring boats, carried out within the framework of port marine services.

2.8 *Shipboard personnel* means personnel assigned duties for supervising or working in mooring areas during mooring operations.

2.9 *Ship Design Minimum Breaking Load (MBL_{SD})* means the minimum breaking load of new, dry, mooring lines for which shipboard fittings and supporting hull structures are designed in order to meet mooring restraint requirements.

2.10 *Supervising personnel* means shipboard personnel assigned duties for supervising mooring areas during mooring operations.

2.11 *Towing and mooring arrangements plan* means the plan as described in section 5 of the annex to the *Revised guidance on shipboard towing and mooring equipment* (MSC.1/Circ.1175/Rev.1). This plan presents specific information regarding the towing and mooring fittings aboard the vessel, the mooring lines, as well as the arrangement of mooring lines and the acceptable environmental conditions for mooring.

2.12 *Working Load Limit (WLL)* means the maximum load that a mooring line should be subjected to in operational service, calculated from the relevant environmental mooring restraint requirement.

3 Goals

The equipment selection and mooring arrangement design safety objectives should be to facilitate safe mooring operations and reduce the risk to shipboard personnel and mooring personnel caused by inappropriate selection and arrangement of equipment and fittings.

4 Functional objectives

4.1 A ship should be provided with mooring equipment and fittings appropriate for its type and size. In addition, a ship should be provided with mooring lines appropriate for the equipment and fittings installed on board. In order to achieve the goals for the correct equipment selection and mooring arrangement design safety objectives set out in section 3, the following functional objectives should be applied.

4.2 Mooring equipment and fittings should be:

- .1 arranged to minimize obstructed access to and operation of the mooring equipment;
- .2 arranged to minimize obstructed access to working space and minimize obstructed view of the mooring area;
- .3 arranged to minimize the need for complex mooring line configurations during the normal operation of the ship;
- .4 selected and arranged to minimize the need for manual handling of mooring lines under load; and
- .5 selected and arranged to minimize the exposure of personnel involved in mooring operations to the dynamic loads of mooring lines.

5 Achievement of the functional objectives

To meet the functional objectives, the following design and equipment features should be considered from the earliest stage in the design process.

Selection of equipment, fittings and mooring lines should not be undertaken independently. To facilitate safe mooring operations, it is necessary for mooring equipment, fittings and mooring lines to be considered as a complete system within which all components are compatible.

The guidance on the design of mooring arrangements and the selection of equipment and fittings should be read in conjunction with MSC.1/Circ.1175/Rev.1.

This section should be implemented to the extent permitted by the size and purpose of the ship.

5.1 Design of mooring arrangements

5.1.1 To minimize the need for complex mooring line configurations during the normal operation of the ship, mooring winches and fairleads should be positioned to allow the use of direct, unobstructed leads from the mooring winch to the fairlead for each of the mooring lines described in the towing and mooring arrangements plan. It is preferable to provide a dedicated fairlead for each mooring line.

5.1.2 Where a straight lead is not possible:

- .1 the deviation from a straight lead should be by means of pedestal fairleads, rolling fairleads or similar means that will reduce friction between line/fitting and reduce bend losses. Steel fittings such as horns or bollards without chafe protection should be avoided;
- .2 the line should traverse the mooring area from winch to the fairlead by the shortest route; and
- .3 changes of direction of mooring line should be minimized to prevent reductions in mooring line strength due to bend loss and introduction of complex snap-back areas.

5.1.3 To provide for the oversight and supervision of the mooring operations, the mooring area should be designed to give supervising personnel an unobstructed view of the installed mooring equipment and fittings. This should include the provision for a platform, or other appropriate means, by which supervising personnel can obtain an unobstructed view of the mooring area and berth arrangements planned to be used from a position clear of hazards.

5.1.4 The mooring arrangements should be designed to provide unobstructed views between shipboard personnel, and of lines being worked, within the mooring area.

5.1.5 The winch operator should be provided with mooring winch controls that are positioned so that the winch operator has a direct view of the line in the mooring area being worked without stepping away from the winch controls. Winch controls should be positioned clear of hazards.

5.1.6 Deck illumination should provide a clear view of the mooring area and the equipment and lines being worked during hours of darkness or in conditions of limited visibility.

5.1.7 The design of mooring arrangements and mooring areas should take into account the following constraints:

- .1 anticipated variations in shore-based mooring arrangements and the need to preserve flexibility in mooring line configurations to achieve an appropriate restraining capacity;
- .2 ships' structural elements, including accommodation, ventilation exhausts, cargo equipment or similar obstacles, on access; and
- .3 special requirements for the location and selection of mooring equipment and fittings, for example special requirements for canal transits.

5.1.8 Unless the size and special features of the ship do not permit it, equipment and fittings in mooring areas should be positioned to provide shipboard personnel with unobstructed access to the following during mooring operations:

- .1 mooring winches and winch controls;
- .2 mooring fittings;
- .3 mooring lines and mooring line stowage; and
- .4 the space between shipside fairleads and winches to permit mooring personnel to safely apply stoppers to mooring lines when necessary.

5.1.9 The mooring arrangements should be designed to avoid the exposure of the shipboard personnel to lines under tension through snap-back or sudden movements of mooring lines. In this respect the following measures should be considered:

- .1 locate winches close to shipside fairleads. The position of winches should not result in inappropriate mooring line orientations, or block or otherwise interfere with the use of shipside fairleads for additional mooring lines, connecting up of tugs for towage during mooring operations or the ability to safely moor the ship;
- .2 enclosing the mooring line(s) behind barrier(s) provided that such enclosures do not adversely affect the performance of the mooring system and do not prevent effective inspection and maintenance of equipment, fittings and mooring lines;
- .3 alternative design(s) where crew members do not need to work close to or have to pass mooring lines under tension or potentially under tension;
- .4 use of appropriate, alternative means to moor the ship, including but not limited to automated mooring systems; or
- .5 permanently fix mooring lines to a mooring winch.

5.1.10 Mooring areas should be considered as potential snap-back zones and signage should be provided to indicate that this is the case.

5.1.11 To minimize the need for manual handling of towing and mooring lines, the following measures should be considered:

- .1 equipment and fitting arrangements should minimize the distance over which any mooring line may need to be handled;
- .2 the use of fixed or dedicated mooring lines, taking into account the need to avoid inappropriate mooring line orientations, or block or otherwise interfere with the use of shipside fairleads for additional mooring lines, connecting up of tugs for towage during mooring operations or the ability to safely moor the ship;
- .3 the layout to be designed to prevent manual intervention in transfer of the mooring line from storage drum to mooring winch drum and vice versa;
- .4 use of spooling equipment;
- .5 additional mooring lines should be available for immediate use, provided that their stowage does not interfere with the safe operation of the mooring equipment; and
- .6 a sufficient number of mooring winches so that, during mooring operations, manual use of warping ends, stoppers, capstans and bitts is minimized, as far as possible.

5.1.12 The mooring arrangement design should take into account the principles for effective mooring arrangements included in appropriate industry guidance on mooring equipment and fittings.

5.2 Selection of equipment, fittings and mooring lines

5.2.1 The selection of winches should take into account:

- .1 the availability of winches with alternative drum arrangements, including split drum arrangements, which can reduce the need for manual handling of mooring lines during mooring operations;
- .2 the positioning of winch controls, including the availability of remote controls for winches to improve the line of sight and reduce operator exposure to snap-back;
- .3 the availability of constant tension winches and their appropriateness for the normal operation of the ship; and
- .4 limiting noise levels to ensure proper communication during mooring operations.

5.2.2 The selection of fittings should take into account:

- .1 the type of mooring line with which the fitting is designed to be used. The design or selection of the fitting and the design of its hull supporting structure should be done in accordance with MSC.1/Circ.1175/Rev.1;

- .2 the diameter D of surfaces of mooring fittings that are in contact with the mooring line in relation to the mooring line diameter d (D/d ratio) to reduce or mitigate bend loss of strength; and
- .3 the need for the load-bearing surfaces of fittings to minimize damage from chafing and abrasion.

5.2.3 The selection of mooring lines should take into account:

- .1 the guidance on mooring restraint as per appendix A of MSC.1/Circ.1175/Rev.1;
- .2 the diameter D of surfaces of mooring fittings that are in contact with the mooring line in relation to the mooring line diameter d (D/d ratio) to reduce or mitigate bend loss of strength;
- .3 the compatibility of the MBL_{SD} of mooring lines and the brake capacity of the mooring winches installed on board;
- .4 the Line Design Break Force (LDBF) to be 100% to 105% of the MBL_{SD} ;
- .5 the characteristics and limitations of mooring lines including material properties and environmental operating conditions anticipated during normal operation of the ship;
- .6 the anticipated behaviour of the mooring line in the event of failure;
- .7 the influence on stored energy and the potential for snap-back of high stiffness mooring lines caused by the use of tails; and
- .8 as far as possible, but at least for lines in the same service (e.g. headlines, breast lines or springs), mooring lines of the same diameter and type (i.e. material) should be used.

5.2.4 To avoid overload on mooring winches, fittings and mooring lines, consideration should be given to select mooring winches with brake capacity of less than the ship design minimum breaking load of the mooring line or with adjustable brake capacity.

5.2.5 Fittings, particularly shipside fairleads, should be positioned to minimize the potential for chafing of mooring lines during the normal operation of the ship.

5.2.6 The selection of equipment and fittings including lines should take into account the principles for effective mooring arrangements included in appropriate industry guidance.

5.2.7 The mooring equipment, fittings and the mooring lines should at all times be compatible in design, diameter, strength, suitability, etc. and maintained with the original purpose and concept of the mooring arrangement.

5.2.8 Load limits

5.2.8.1 Notwithstanding the definitions in paragraph 2.1, LDBF of mooring lines made of nylon should be tested under wet and spliced conditions.

5.2.8.2 All components of a ship's mooring system, within defined tolerances, should be selected based on MBL_{SD} .

5.2.8.3 When selecting lines, the LDBF should be 100% to 105% of the MBL_{SD} .

5.2.8.4 The WLL of mooring lines should be used as user operating limiting values, not to be exceeded. The WLL is expressed as a percentage of MBL_{SD} and should be used as a limiting value in operational mooring analyses. Steel wires have a WLL of 55% of MBL_{SD} and all other cordage (synthetic) have a WLL of 50% of the MBL_{SD} .

6 Documentation on deviation

6.1 A supplement to the "Towing and mooring arrangements plan" should record the deviations if any, in relation to the following paragraphs:

- .1 5.1.2 (where a straight lead is not possible);
- .2 5.1.4 (unobstructed views);
- .3 5.1.5 (protection of winch operators);
- .4 5.1.8 (access to mooring equipment and fitting);
- .5 5.1.9 (exposure of the shipboard personnel to lines under tension); and
- .6 5.1.11 (minimize the need for manual handling of towing and mooring lines).

6.2 The documentation should include justification for such deviations and suitable safety measures, if any.

6.3 A reference to the supplement should be included in the towing and mooring arrangement plan so as to make the shipboard personnel aware of the safety measures which need to be considered during mooring operations.

7 References

- (1) Oil Companies International Marine Forum (OCIMF), *Mooring Equipment Guidelines, 4th Edition 2018*, ISBN: 978-1-85609-771-0.
- (2) Ian. C. Clark BSc, MSc, Master Mariner, MNI, *The Nautical Institute, Mooring and Anchoring Ships Vol.1, Principle and Practice*, ISBN: 9781906915934, 2009.

4 ALBERT EMBANKMENT
LONDON SE1 7SR
Telephone: +44 (0)20 7735 7611 Fax: +44 (0)20 7587 3210

MSC.1/Circ.1620
24 December 2020

**GUIDELINES FOR INSPECTION AND MAINTENANCE OF
MOORING EQUIPMENT INCLUDING LINES**

- 1 The Maritime Safety Committee, at its 102nd session (4 to 11 November 2020), having considered a proposal by the Sub-Committee on Ship Design and Construction, at its sixth session, and recognizing the importance of inspection and maintenance of mooring equipment including lines, approved the *Guidelines for inspection and maintenance of mooring equipment including lines*, as set out in the annex.
- 2 Member States are invited to bring the annexed Guidelines to the attention of shipowners, ship managers, bareboat charterers and other organizations or persons responsible for operation of ships.
- 3 Member States are also invited to bring the annexed Guidelines to the attention of shipmasters, ships' officers and crew and all other parties concerned, for providing guidance on inspection and maintenance of mooring equipment including mooring lines.

ANNEX

GUIDELINES FOR INSPECTION AND MAINTENANCE OF MOORING EQUIPMENT INCLUDING LINES

1 General

1.1 Purpose

The purpose of these Guidelines is to provide recommendations and guidance for maintenance and in-service inspections of mooring equipment including lines and tails, criteria for identifying worn-out lines and tails for removal from service before failure, and criteria for selection of replacement mooring lines and tails.

1.2 Application

These Guidelines apply to all ships. Certain provisions are intended for reference by shipboard personnel, and other provisions are intended for Company personnel responsible for selecting and procuring replacement mooring lines.

2 Definitions

For the purpose of these Guidelines:

2.1 *Bend radius (D/d ratio)* means the diameter, D, of a mooring fitting divided by the diameter, d, of a mooring line that is led around or through the fitting. The D/d ratio is used by mooring line manufacturers to specify the minimum radius of a fitting around or through which a mooring line of diameter "d" should be led, in order to reduce or mitigate bend loss of strength of the mooring line.

2.2 *Company* means company, as defined in SOLAS regulation IX/1.2.

2.3 *Line Design Break Force (LDBF)* means the minimum force that a new, dry, spliced, mooring line will break at. This is for all synthetic cordage materials.

2.4 *Mooring arrangement* means the configuration of the mooring equipment and fittings and other design features of the ship related to the mooring operation, i.e. lighting and communication equipment.

2.5 *Mooring boat* means the boat handling mooring lines between the ship and ashore mooring facilities during mooring and unmooring operations and does not include harbour ship assist tugs (see the *Guidelines on minimum training and education of mooring personnel* (FAL.6/Circ.11/Rev.1)).

2.6 *Mooring equipment and fittings* means items such as winches, capstans, bollards, bitts, fairleads, rollers, chocks, etc. and also includes mooring lines.

2.7 *Mooring line configuration* means all components of an individual mooring line, including tails, eye splices, etc. Any change or replacement of a component is a change to the line's configuration, unless a component is replaced by a part having the same specification as in the original configuration.

2.8 *Mooring operations* means normal mooring and unmooring of the ship, including associated in-harbour towing movements.

2.9 *Mooring personnel* means personnel tasked to assist in the activity of mooring and unmooring ships, either ashore or from mooring boats, carried out within the framework of port marine services.

2.10 *Rotation of mooring lines* means periodical change of mooring lines for respective mooring drums to equalize the wear of mooring lines.

2.11 *Ship Design Minimum Breaking Load* (MBL_{SD}) means the minimum breaking load of new, dry, mooring lines for which shipboard fittings and supporting hull structures are designed in order to meet mooring restraint requirements.

2.12 *Towing and mooring arrangements plan* means the plan as described in section 5 of the annex to the *Revised guidance on shipboard towing and mooring equipment* (MSC.1/Circ.1175/Rev.1). This plan presents specific information regarding the towing and mooring fittings aboard the vessel, the mooring lines, as well as the arrangement of mooring lines and the acceptable environmental conditions for mooring.

3 Safe use of mooring equipment

3.1 Safe use of mooring equipment and fittings

Throughout its operational life, mooring equipment should be maintained and operated in accordance with the original design concept, if available, including when replacing parts and lines. In order to ensure all mooring equipment functions as designed, the Company should establish procedures for mooring operations, inspection and maintenance of mooring equipment, including mooring lines, taking into account appropriate references listed in paragraph 7 of these Guidelines.

3.2 Protection and storage of mooring lines

To preserve the design life of mooring lines, the following practices should be followed during mooring operations:

- .1 smooth contacts at turn-off points with large angles and/or eye splices; and
- .2 using covers/mats at ship side to protect against any friction damage.

3.3 Control of mooring lines

3.3.1 The Company should establish procedures to allow the identification and control of mooring lines, tails and associated attachments when on board and to facilitate inspection and maintenance of mooring lines. Such procedures should include:

- .1 providing a means of recording the number, type and location of mooring lines, tails and associated attachments. Such records may be included in either the towing and mooring arrangements plan or with records of inspection and maintenance or an alternative established by the requirements of the Company; and
- .2 providing a means of linking specific mooring lines, tails and associated attachments to the relevant records and a manufacturer's certificate, if available.

3.3.2 Any defect discovered to the mooring lines during mooring operations should be immediately reported to the Master by all parties concerned including shore-based mooring personnel. If no actions are taken as appropriate the competent authorities should be informed, as necessary.

4 Inspection and maintenance of mooring lines

4.1 Inspection of mooring lines

4.1.1 To prevent the deterioration of mooring lines to a condition which may result in the failure of the line during mooring operations, the periodic inspection of mooring lines, mooring line tails and associated attachments should be included in the onboard maintenance plan or equivalent maintenance management system. The maintenance plan may be computer based.

4.1.2 The requirements for inspection of individual mooring lines will be specific to the type of mooring line used on board. In general, onboard inspection of mooring lines will be based on manufacturer recommendations and by visual inspection of the outside of the mooring line to identify excessive wear or damage, e.g. external abrasion, external cut, kink, heat damage such as fusion and slackening or fraying of eye splices. Such visual inspections should be based on:

- .1 the recommendations of the mooring line and/or tail manufacturer, particularly the criteria provided for the assessment of mooring line condition;
- .2 operational experience regarding the performance of the mooring line and/or mooring line tail during previous mooring operations; and
- .3 the environmental conditions to which the mooring lines and/or mooring line tails are routinely exposed.

4.1.3 In the case of jacketed synthetic fibre mooring lines, detailed visual inspection of the condition of the synthetic fibre line may not be possible. The condition of the external jacket is not an accurate indicator of the condition of the load-bearing synthetic fibre material within the mooring line.

4.2 Maintenance of mooring lines

The Company should establish the maintenance procedures as required in paragraph 3.1 of these Guidelines. The maintenance procedures should specify replacement of in-service mooring lines and may include the rotation of mooring lines.

4.3 Criteria for condemning worn-out mooring lines

4.3.1 The replacement of in-service mooring lines which have been assessed as no longer suitable for use should be based on the removal prior to failure and in accordance with criteria provided by the manufacturer.

4.3.2 For visual inspection and replacement of mooring lines, additional advice is provided in industry guidance on mooring line and mooring line tail inspections.

4.4 Inspection and maintenance of equipment and fittings

4.4.1 Equipment and fittings should be properly inspected and maintained, based on the manufacturer's recommendations. Mooring equipment and fittings should be included in the onboard maintenance plan or equivalent maintenance management system. The maintenance plan may be computer based.

4.4.2 Maintenance should include the preservation, by appropriate means, of the clear marking of information on equipment and fittings, including Safe Working Load (SWL) and winch control instructions.

4.4.3 Records of inspection and maintenance of equipment and fittings should be available on board.

4.4.4 Records of the original design concept, equipment, arrangement and specifications should be retained on board through the life cycle of the ship.

4.4.5 To preserve the design life of mooring lines and reduce the potential for failure during mooring operations any storage provided for additional (loose) mooring lines should minimize the exposure to harmful environments (e.g. UV light, water, chemicals, cargo, extreme temperature).

5 Selection of replacement mooring lines

5.1 When replacing mooring lines, compatibility with the mooring equipment and fittings on board, as specified in the mooring arrangement plan, should be taken into account. This should be achieved by selecting a replacement mooring line which meets the designed specifications. In cases where this is not possible, the following properties should be taken into consideration and the towing and mooring arrangement plan updated accordingly:

- .1 breaking strength;
- .2 environmental conditions to be used (e.g. temperature);
- .3 linear density;
- .4 tenacity;
- .5 D/d ratios;
- .6 compression fatigue; and
- .7 stiffness.

5.2 Any increase in LDBF for the mooring lines above the limits specified, i.e. 100% to 105% of the MBL_{SD} , may require a review of the operating parameters and load limits of mooring equipment and fitting as well as of their hull supporting structures.

5.3 It should be noted that, when selecting replacement mooring lines, over time in service their strength will decay due to varying environmental conditions and thus the original service life expectations may not be achieved. Therefore, the Company should ensure that the condition of mooring lines is tracked throughout their service with the objective to replace the line before failure.

5.4 For wire ropes, corrosion protection should be considered.

5.5 For both wire and fibre mooring lines, the acceptable minimum bend radius (D/d ratio) recommended by the manufacturer should be taken into consideration as strength and life expectancy of these lines are directly related to the bend radius they are exposed to in service.

5.6 Where the acceptable minimum bend radius recommendations for a particular mooring line are not achievable, the service life of the line may be less than that stated by the manufacturer and therefore the line may need to be replaced before the end of the service life recommended by the manufacturer. The condition of lines regularly exposed to below the acceptable minimum bend radius should be subject to particular attention during inspections.

5.7 When selecting replacement mooring lines with high stiffness, including wire and high modulus synthetic lines, consideration should be given to the use of synthetic tails in order to reduce peak loading when the ship is secured alongside.

5.8 Consideration of the use of synthetic tails on high stiffness mooring lines should take into account industry and manufacturer guidance and the potential effects of synthetic tails on the stored energy of mooring lines under tension. The use of tails can change the characteristics of a mooring line and its behaviour in the event of failure. High stiffness mooring lines may exert significant dynamic force and have significant snap-back zones when used with synthetic tails that have a low stiffness.

6 Updating of ship documents and record-keeping

6.1 Records of inspection and maintenance of mooring equipment and inspection and replacement of mooring lines should be retained on board. Such records should be kept for a period determined by the Company, but in any event the records should be kept until completion of the next annual survey.

6.2 Consideration should be given to control and certification of mooring lines, wires, tails and associated attachments. Manufacturers' test certificates for mooring lines, joining shackles and synthetic tails should be kept on board and properly linked back to the equipment.

6.3 The items to be recorded during inspection and maintenance should be determined, taking into account the recommendations of the manufacturers of the mooring lines.

6.4 Any change of mooring line configuration requires updating of the towing and mooring arrangements plan.

7 References

- (1) Oil Companies International Marine Forum (OCIMF), *Mooring Equipment Guidelines, 4th Edition 2018*, ISBN: 978-1-85609-771-0.
- (2) Ian. C. Clark BSc, MSc, Master Mariner, MNI, *The Nautical Institute, Mooring and Anchoring Ships Vol.1, Principle and Practice*, ISBN: 9781906915934, 2009.
- (3) Walter Vervloesem AMNI, *The Nautical Institute, Mooring and Anchoring Ships Vol.2, Inspection and Maintenance*, ISBN: 9781870077941, 2009.

INTERNATIONAL MARITIME ORGANIZATION
4 ALBERT EMBANKMENT
LONDON SE1 7SR

Telephone: 020 7587 3152
Fax: 020 7587 3210



IMO

E

Ref. T4/3.01

MSC/Circ.1175
24 May 2005

GUIDANCE ON SHIPBOARD TOWING AND MOORING EQUIPMENT

1 The Maritime Safety Committee, at its eightieth session (11 to 20 May 2005), following the recommendations made by the Sub-Committee on Ship Design and Equipment at its forty-eighth session, approved guidance concerning shipboard equipment, fittings and supporting hull structures associated with towing and mooring, as set out in the annex, with a view to ensuring a uniform approach towards the application of the provisions of SOLAS regulation II-1/3-8, which is expected to become effective on 1 January 2007.

2 Member Governments are invited to use the annexed guidance when applying SOLAS regulation II-1/3-8, and to bring it to the attention of all parties concerned.

ANNEX

SHIPBOARD EQUIPMENT, FITTINGS AND SUPPORTING HULL STRUCTURES ASSOCIATED WITH TOWING AND MOORING

1 Application

1.1 Under regulation II-1/3-8 of the 1974 SOLAS Convention, as adopted by resolution MSC.194(80) in 2005, new displacement type ships, except high-speed craft and offshore units, shall be provided with arrangements, equipment and fittings of sufficient safe working load to enable the safe conduct of all towing and mooring operations associated with the normal operations of the ship. The arrangements, equipment and fittings shall meet the appropriate requirements of the Administration or an organization recognized by the Administration.

1.2 This circular is intended to provide standards for the design and construction of shipboard fittings and supporting hull structures associated with towing and mooring, which Administrations are recommended to implement. The provisions of this guidance do not require tow lines nor mandate standards for mooring lines onboard the ship.

1.3 Equipment that is used for both towing and mooring should be in accordance with sections 3 and 4.

2 Definitions

For the purpose of this guidance:

2.1 *Shipboard fittings* mean bollards and bitts, fairleads, stand rollers and chocks used for the normal mooring of the ship and similar components used for the normal towing of the ship. Other components such as capstans, winches, etc. are not covered by this guidance. Any weld, bolt or other fastening connecting the shipboard fitting to the supporting hull structure is part of the shipboard fitting and subject to any industry standard applicable to such fitting.

2.2 *Supporting hull structure* means that part of the ship structure on/in which the shipboard fitting is placed and which is directly submitted to the forces exerted on the shipboard fitting. The hull structure supporting capstans, winches, etc. used for the normal towing and mooring operations mentioned above should also be subject to this guidance.

2.3 *Industry standard* means international or national standards which are recognized in the country where the ship is built, subject to the approval of the Administration.

3 Towing fittings

3.1 Strength

The strength of shipboard fittings used for normal towing operations and their supporting hull structures should comply with the provisions of 3.2 to 3.6.

3.2 Arrangements

Shipboard fittings for towing should be located on longitudinals, beams and/or girders, which are part of the deck construction so as to facilitate efficient distribution of the towing load. Other equivalent arrangements may be accepted (for Panama chocks, etc.).

3.3 Load considerations

3.3.1 The design load used for normal towing operations (e.g. harbour/manoeuvring) should be 1.25 times the intended maximum towing load (e.g. static bollard pull) as indicated on the towing and mooring arrangements plan. The design load should be applied through the tow line according to the arrangement shown on the towing and mooring arrangements plan.

3.3.2 For other towage service (e.g. escort), the design load used for each fitting should be the nominal breaking strength of the tow line defined in table 1 based on the equipment number (EN) described in the appendix. The design load should be applied through the tow line according to the arrangement shown on the towing and mooring arrangements plan.

3.3.3 The method of application of the design load to the fittings and supporting hull structure should be taken into account such that the total load need not be more than twice the design load specified in 3.3.1 or 3.3.2, i.e. no more than one turn of one line (see figure below).

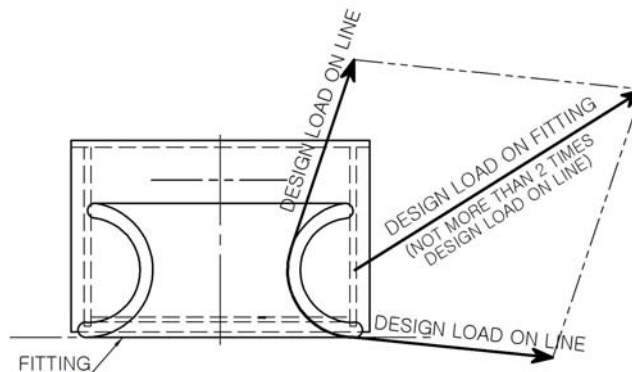

3.4 Shipboard fittings

The selection of shipboard fittings should be made by the shipyard in accordance with industry standards (e.g. ISO 3913:1977 Shipbuilding-Welded steel bollards) accepted by the Administration. When the shipboard fitting is not selected from an accepted industry standard, the design load used to assess its strength and its attachment to the ship should be in accordance with 3.3 above.

3.5 Supporting hull structure

Arrangement

3.5.1 The arrangement of the reinforced members (carling) beneath shipboard fittings should consider any variation of direction (laterally and vertically) of the towing forces (which should be not less than the design load as per 3.3) acting through the arrangement of connection to the shipboard fittings.

Acting point of towing force

3.5.2 The acting point of the towing force on shipboard fittings should be taken at the attachment point of a towing line or at a change in its direction.

Allowable stresses

3.5.3 Allowable bending stress: 100% of the specified yield point for the material used; allowable shearing stress: 60% of the specified yield point for the material used; no stress concentration factors being taken into account.

3.6 Safe working load (SWL)

3.6.1 The SWL used for normal towing operations (harbour/manoeuvring) should not exceed 80% of the design load as given in 3.3.1 and the SWL used for other towing operations (e.g. escort) should not exceed the design load as given in 3.3.2. For fittings used for both harbour and escort purposes, the greater of the design loads of 3.3.1 and 3.3.2 should be used.

3.6.2 The SWL of each shipboard fitting should be marked (by weld bead or equivalent) on the deck fittings used for towing.

3.6.3 The above provisions on SWL apply for a single post basis (no more than one turn of one line).

3.6.4 The towing and mooring arrangements plan described in section 5 should define the method of use of towing lines.

4 Mooring fittings

4.1 Strength

The strength of shipboard fittings used for mooring operations and their supporting hull structures should comply with the provisions of 4.2 to 4.6.

4.2 Arrangements

Shipboard fittings for mooring should be located on longitudinals, beams and/or girders, which are part of the deck construction so as to facilitate efficient distribution of the mooring load. Other equivalent arrangements may be accepted (for Panama chocks, etc.).

4.3 Load considerations

4.3.1 The design load applied to shipboard fittings and supporting hull structures should be 1.25 times the breaking strength of the mooring line provided in accordance with table 1 based on the equipment number (EN) described in the appendix. The design load should be applied through the mooring line according to the arrangement shown on the towing and mooring arrangements plan.

4.3.2 The design load applied to supporting hull structures for winches, etc. should be 1.25 times the breaking strength of the mooring line according to 4.3.1 above and, for capstans, 1.25 times the maximum hauling-in force. The design load should be applied through the mooring line according to the arrangement shown on the towing and mooring arrangements plan.

4.3.3 The method of application of the design load to the fittings and supporting hull structure should be taken into account such that the total load need not be more than twice the design load specified in 4.3.1, i.e. no more than one turn of one line.

4.4 Shipboard fittings

The selection of shipboard fittings should be made by the shipyard in accordance with industry standards (e.g. ISO 3913:1977 Shipbuilding-Welded steel bollards) accepted by the Administration. When the shipboard fitting is not selected from an accepted industry standard, the fittings should be equivalent to a recognized industry standard in compliance with the design load as per 4.3.

4.5 Supporting hull structure

Arrangement

4.5.1 The arrangement of the reinforced members (carling) beneath shipboard fittings should consider any variation of direction (laterally and vertically) of the mooring forces (which should be not less than the design load given in 4.3) acting through the arrangement of connection to the shipboard fittings.

Acting point of mooring force

4.5.2 The acting point of the mooring force on shipboard fittings should be taken at the attachment point of a mooring line or at a change in its direction.

Allowable stresses

4.5.3 Allowable bending stress: 100% of the specified yield point for the material used; allowable shearing stress: 60% of the specified yield point for the material used; no stress concentration factors being taken into account.

4.6 Safe working load (SWL)

4.6.1 The SWL should not exceed 80% of the design load given in 4.3.

4.6.2 The SWL of each shipboard fitting should be marked (by weld bead or equivalent) on the deck fittings used for mooring.

4.6.3 The above provisions on SWL apply for a single post basis (no more than one turn of one line).

4.6.4 The towing and mooring arrangements plan described in section 5 should define the method of use of mooring lines.

5 Towing and mooring arrangements plan

5.1 The SWL for the intended use for each shipboard fitting should be noted in the towing and mooring arrangements plan available on board for the guidance of the Master.

5.2 Information provided on the plan should include in respect of each shipboard fitting:

- .1 location on the ship;
- .2 fitting type;
- .3 SWL;
- .4 purpose (mooring/harbour towing/escort towing); and
- .5 method of applying load of towing or mooring line including limiting fleet angles.

Table 1
MOORING AND TOW LINES

EQUIPMENT NUMBER		MOORING LINES	TOW LINE*
Exceeding	Not exceeding	Minimum breaking strength (kN)	Breaking strength (kN)
<i>1</i>	<i>2</i>	<i>3</i>	<i>4</i>
50	70	34	98
70	90	37	98
90	110	39	98
110	130	44	98
130	150	49	98
150	175	54	98
175	205	59	112
205	240	64	129
240	280	69	150
280	320	74	174
320	360	78	207
360	400	88	224
400	450	98	250
450	500	108	277
500	550	123	306
550	600	132	338
600	660	147	370
660	720	157	406
720	780	172	441
780	840	186	479
840	910	201	518
910	980	216	559
980	1060	230	603
1060	1140	250	647
1140	1220	270	691
1220	1300	284	738
1300	1390	309	786
1390	1480	324	836
1480	1570	324	888
1570	1670	333	941
1670	1790	353	1024
1790	1930	378	1109
1930	2080	402	1168
2080	2230	422	1259
2230	2380	451	1356
2380	2530	480	1453
2530	2700	480	1471
2700	2870	490	1471
2870	3040	500	1471
3040	3210	520	1471
3210	3400	554	1471

EQUIPMENT NUMBER		MOORING LINES	TOW LINE*
Exceeding	Not exceeding	Minimum breaking strength (kN)	Breaking strength (kN)
<i>1</i>	<i>2</i>	<i>3</i>	<i>4</i>
3400	3600	588	1471
3600	3800	618	1471
3800	4000	647	1471
4000	4200	647	1471
4200	4400	657	1471
4400	4600	667	1471
4600	4800	677	1471
4800	5000	686	1471
5000	5200	686	1471
5200	5500	696	1471
5500	5800	706	1471
5800	6100	706	1471
6100	6500	716	
6500	6900	726	
6900	7400	726	
7400	7900	726	
7900	8400	736	
8400	8900	736	
8900	9400	736	
9400	10000	736	
10000	10700	736	
10700	11500	736	
11500	12400	736	
12400	13400	736	
13400	14600	736	
14600	16000	736	

* Information is provided in relation to 3.3.2 and provision onboard of such a line is not necessary under this guidance.

APPENDIX

EQUIPMENT NUMBER

The equipment number (EN) should be calculated as follows:

$$EN = \Delta^{2/3} + 2.0hB + \frac{A}{10}$$

where:

Δ = moulded displacement, in tonnes, to the Summer Load Waterline

B = moulded breadth, in metres

h = effective height, in metres, from the Summer Load Waterline to the top of the uppermost house; for the lowest tier "h" should be measured at centreline from the upper deck or from a notional deck line where there is local discontinuity in the upper deck

$$h = a + \sum h_i$$

where:

a = distance, in metres, from the Summer Load Waterline amidships to the upper deck

h_i = height, in metres, on the centreline of each tier of houses having a breadth greater than B/4

A = area, in square metres, in profile view, of the hull, superstructures and houses above the Summer Load Waterline which are within the equipment length of the ship and also have a breadth greater than B/4

NOTES

- 1 When calculating h, sheer and trim should be ignored, i.e. h is the sum of freeboard amidships plus the height (at centreline) of each tier of houses having a breadth greater than B/4.
- 2 If a house having a breadth greater than B/4 is above a house with a breadth of B/4 or less, then the wide house should be included but the narrow house ignored.
- 3 Screens or bulwarks 1.5 m or more in height should be regarded as parts of houses when determining h and A. The height of the hatch coamings and that of any deck cargo, such as containers, may be disregarded when determining h and A. With regard to determining A, when a bulwark is more than 1.5 m high, the area shown below as A₂ should be included in A.

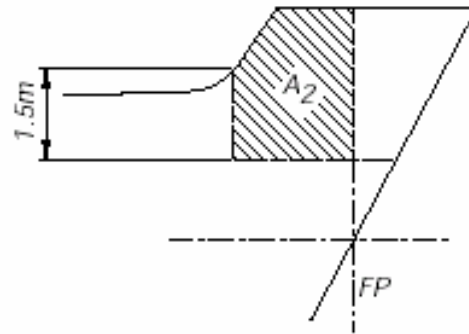

- 4 The equipment length of the ships is the length between perpendiculars but should not be less than 96% nor greater than 97% of the extreme length on the Summer Waterline (measured from the forward end of the waterline).

4 ALBERT EMBANKMENT
LONDON SE1 7SR
Telephone: +44 (0)20 7735 7611 Fax: +44 (0)20 7587 3210

MSC.1/Circ.1175/Rev.1*
9 December 2020

REVISED GUIDANCE ON SHIPBOARD TOWING AND MOORING EQUIPMENT

1 The Maritime Safety Committee, at its eightieth session (11 to 20 May 2005), approved guidance concerning shipboard equipment, fittings and supporting hull structures associated with towing and mooring for the uniform implementation of SOLAS regulation II-1/3-8, adopted by resolution MSC.194(80), which became effective on 1 January 2007.

2 The Committee, at its 102nd session (4 to 11 November 2020), having considered a proposal by the Sub-Committee on Ship Design and Construction, at its sixth session, with a view to ensuring a uniform approach towards the application of the provisions of SOLAS regulation II-1/3-8, as amended by resolution MSC.474(102), which is expected to become effective on 1 January 2024, approved the *Revised guidance on shipboard towing and mooring equipment*, as set out in the annex.

3 This revised guidance is applicable to ships constructed on or after 1 January 2024 and does not supersede the *Guidance on shipboard towing and mooring equipment* (MSC.1/Circ.1175) which remains applicable to ships constructed on or after 1 January 2007 but before 1 January 2024.

4 Member Governments are invited to use the annexed guidance when applying the revised SOLAS regulation II-1/3-8, and to bring it to the attention of all parties concerned.

* Re-issued to refer to the correct resolution MSC.474(102) in paragraph 2 of the cover sheet.

ANNEX

SHIPBOARD EQUIPMENT, FITTINGS AND SUPPORTING HULL STRUCTURES ASSOCIATED WITH TOWING AND MOORING

1 Application

1.1 Under regulation II-1/3-8 of the 1974 SOLAS Convention, as adopted by resolution MSC.473(102), new displacement type ships, except high-speed craft and offshore units, shall be provided with arrangements, equipment and fittings of sufficient safe working load to enable the safe conduct of all towing and mooring operations associated with the normal operations of the ship. The arrangements, equipment and fittings shall meet the appropriate requirements of the Administration or an organization recognized by the Administration.

1.2 The *Revised guidance on shipboard towing and mooring equipment* (MSC.1/Circ.1175/Rev.1) should apply to ships constructed on or after 1 January 2024. To ships constructed on or after 1 January 2007 and before 1 January 2024, the *Guidance on shipboard towing and mooring equipment* (MSC.1/Circ.1175) should apply.

1.3 This circular provides standards for the design and construction of shipboard fittings and supporting hull structures associated with normal towing and mooring operations in harbours or sheltered waters, which Administrations are recommended to implement. This circular also contains design guidance for fittings of ships that are further intended to be towed by another ship or tug, e.g. in an emergency. This circular does not require tow lines nor mandate standards for mooring lines on board the ship. Furthermore, this guidance is not applicable to the design and construction of shipboard fittings and supporting hull structures used for special towing services defined as:

- .1 *Escort towing*: Towing service required in some estuaries to control the ship in case of failures of the propulsion or steering system. It should be referred to local escort requirements;
- .2 *Canal transit towing*: Towing service for ships transiting canals, e.g. the Panama Canal. It should be referred to local canal transit requirements; and
- .3 *Emergency towing for tankers*: Towing service to assist tankers in case of emergency. It should be referred to paragraph 1 of SOLAS regulation II-1/3-4.

1.4 Equipment that is used for both towing and mooring should be in accordance with sections 3 and 4.

2 Definitions

For the purpose of this guidance:

2.1 *Normal towing* means towing operations necessary for manoeuvring in ports and sheltered waters associated with the normal operations of the ship.

2.2 *Other towing* means towing by another ship or a tug, such as to assist the ship in case of emergency.

2.3 *Shipboard fittings* mean bollards and bitts, fairleads, pedestal rollers and chocks used for mooring of the ship and similar components used for normal or other towing of the ship. Any weld, bolt or other fastening connecting the shipboard fitting to the supporting hull structure is part of the shipboard fitting and subject to any industry standard applicable to such fitting.

2.4 *Supporting hull structure* means that part of the ship structure on/in which the shipboard fitting is placed and which is directly submitted to the forces exerted on the shipboard fitting. The hull structure supporting capstans, winches, etc. used for normal or other towing and mooring operations mentioned above should also be subject to this guidance.

2.5 *Industry standard* means international or national standards which are recognized in the country where the ship is built, subject to the approval of the Administration.

2.6 *Safe working load (SWL)* means the safe load limit of shipboard fittings used for mooring operations in harbours or similar sheltered waters.

2.7 *Safe towing load (TOW)* means the safe load limit of shipboard fittings used for normal and other towing.

2.8 *Ship Design Minimum Breaking Load (MBL_{SD})* means the minimum breaking load of new, dry mooring lines for which shipboard fittings and supporting hull structures are designed in order to meet mooring restraint requirements.

3 Towing

3.1 Strength

The strength of shipboard fittings used for normal towing operations and their supporting hull structures should comply with the provisions of 3.2 to 3.6. Where a ship is equipped with shipboard fittings intended to be used for other towing services, the strength of these fittings and their supporting hull structures should also comply with these provisions. The strength of shipboard fittings intended to be used for both towing and mooring and of their supporting hull structures should also comply with the provisions of section 4.

3.2 Arrangements

Shipboard fittings for towing should be located on stiffeners and/or girders which are part of the deck construction so as to facilitate efficient distribution of the towing load. Other equivalent arrangements may be accepted (for chocks in bulwarks, etc.), provided the strength is confirmed as adequate for the intended service.

3.3 Load considerations

3.3.1 The minimum design load applied to supporting hull structures for shipboard fittings should be:

- .1 for normal towing operations, 1.25 times the intended maximum towing load (e.g. static bollard pull), as indicated on the towing and mooring arrangements plan;
- .2 for other towing services, the ship design minimum breaking load of the tow line defined in appendix A; and
- .3 for fittings intended to be used for both normal and other towing operations, the greater of the design loads according to .1 and .2.

3.3.2 The design load should be applied to fittings in all directions that may occur by taking into account the arrangement shown on the towing and mooring arrangements plan. Where the towing line takes a turn at a fitting, the total design load applied to the fitting is equal to the resultant of the design loads acting on the line. However, in no case does the design load applied to the fitting need to be more than twice the design load on the line as specified in 3.3.1 (see figure below).

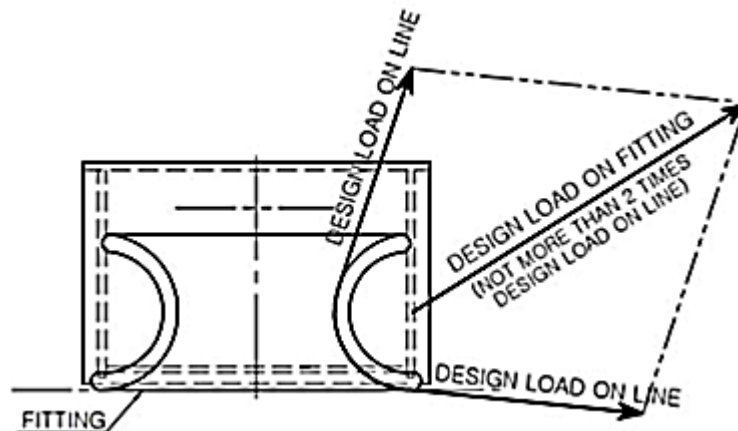

3.4 Shipboard fittings

3.4.1 Shipboard fittings may be selected from an industry standard accepted by the Administration and at least based on the following loads:

- .1 for normal towing operations, the intended maximum towing load (e.g. static bollard pull) as indicated on the towing and mooring arrangements plan;
- .2 for other towing services, the ship design minimum breaking load of the tow line according to appendix A; and
- .3 for fittings intended to be used for both normal and other towing operations, the greater of the loads according to .1 and .2.

3.4.2 When the shipboard fitting is not selected from an accepted industry standard, the strength of the fitting and of its attachment to the supporting hull structure should be in accordance with 3.3 and 3.5.

3.5 Supporting hull structure

3.5.1 The reinforcing members beneath shipboard fittings should be effectively arranged for any variation of direction (horizontally and vertically) of the towing forces acting upon the shipboard fittings. Proper alignment of fitting and supporting hull structures should be ensured.

3.5.2 The acting point of the towing force on shipboard fittings should be taken at the attachment point of a towing line or at a change in its direction. For bollards and bits the attachment point of the towing line should be taken not less than 4/5 of the tube height above the base (see figure below).

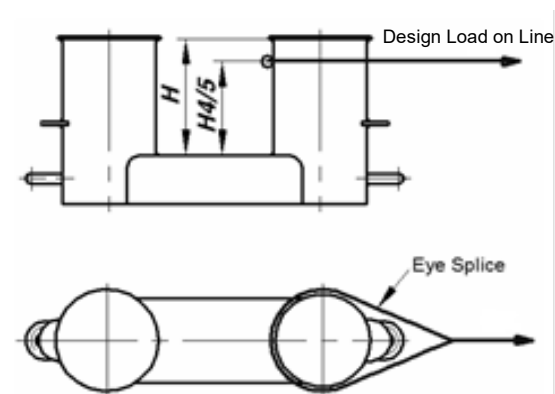

3.5.3 Under the design load conditions as specified in 3.3 the allowable normal stress should be taken as 100% and the allowable shearing stress as 60% of the specified yield point for the material used. Normal stress is the sum of bending stress and axial stress with the corresponding shearing stress acting perpendicular to the normal stress. No stress concentration factors being taken into account.

3.6 Safe towing load (TOW)

3.6.1 TOW used for normal towing operations should not exceed 80% of the design load as given in 3.3.1.1 and TOW used for other towing operations should not exceed 80% of the design load as given in 3.3.1.2. For fittings used for both, normal and other towing operations, the greater of the safe towing loads should be used.

3.6.2 TOW, in tonnes, of each shipboard fitting should be marked (by weld bead or equivalent) on the fittings intended for towing. For fittings intended to be used for both, towing and mooring, SWL, in tonnes, according to 4.6, should be marked in addition to TOW.

3.6.3 The above provisions on TOW apply for the use of no more than one towing line.

3.6.4 The towing and mooring arrangements plan described in section 5 should define the method of use of towing lines.

4 Mooring

4.1 Strength

The strength of shipboard fittings used for mooring operations and of their supporting hull structures, as well as the strength of supporting hull structures of winches and capstans, should comply with the provisions of 4.2 to 4.6. The strength of shipboard fittings, intended to be used for both, mooring and towing, and of their supporting hull structures, should also comply with the provisions of section 3.

4.2 Arrangements

Shipboard fittings, winches and capstans for mooring should be located on stiffeners and/or girders, which are part of the deck construction, so as to facilitate efficient distribution of the mooring load. Other equivalent arrangements may be accepted (for chocks in bulwarks, etc.) provided the strength is confirmed adequate for the service.

4.3 Load considerations

4.3.1 The minimum design load applied to supporting hull structures:

- .1 of shipboard fittings should be 1.15 times the ship design minimum breaking load of the mooring line provided in accordance with appendix A;
- .2 of winches should be 1.25 times the intended maximum brake holding load, where the maximum brake holding load should be assumed not less than 80% of the ship design minimum breaking load of the mooring line according to appendix A; and
- .3 of capstans 1.25 times the maximum hauling-in force.

4.3.2 The design load should be applied to fittings in all directions that may occur by taking into account the arrangement shown on the towing and mooring arrangements plan. Where the mooring line takes a turn at a fitting, the total design load applied to the fitting is equal to the resultant of the design loads acting on the line. However, in no case does the design load need to be more than twice the design load on the line as specified in 4.3.1 (see figure in 3.3).

4.4 Shipboard fittings

4.4.1 Shipboard fittings may be selected from industry standards accepted by the Administration at least based on the ship design minimum breaking load of the mooring line according to appendix A.

4.4.2 When the shipboard fitting is not selected from an accepted industry standard, the strength of the fittings and of its attachment to the supporting hull structure should be in accordance with 4.3 and 4.5.

4.5 Supporting hull structure

4.5.1 Arrangement of reinforcing members beneath shipboard fittings, winches and capstans should consider any variation of direction (horizontally and vertically) of the mooring forces acting upon the shipboard fittings. Proper alignment of fitting and supporting hull structures should be ensured.

4.5.2 The acting point of the mooring force on shipboard fittings should be taken at the attachment point of a mooring line or at a change in its direction. For bollards and bits the attachment point of the mooring line should be taken not less than 4/5 of the tube height above the base (see figure a) below). However, if fins are fitted to the bollard tubes to keep the mooring line as low as possible, the attachment point of the mooring line may be taken at the location of the fins (see figure b) below).

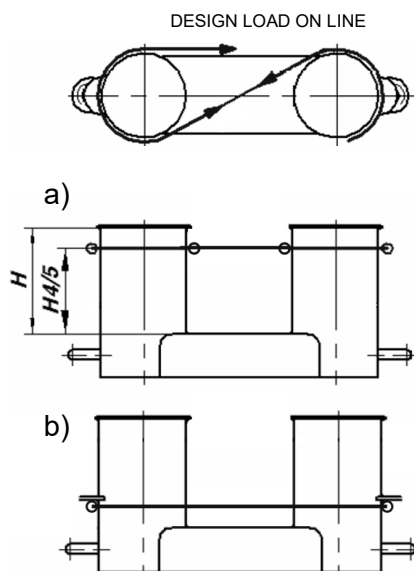

4.5.3 Under the design load conditions, as specified in 4.3, the allowable normal stress should be taken as 100% and the allowable shearing stress as 60% of the specified yield point for the material used. Normal stress is the sum of bending stress and axial stress with the corresponding shearing stress acting perpendicular to the normal stress, no stress concentration factors being taken into account.

4.6 Safe working load (SWL)

4.6.1 The SWL, for the purpose of marking, should be equal to the ship design minimum breaking load of the mooring line according to appendix A.

4.6.2 The SWL, in tonnes, of each shipboard fitting should be marked (by weld bead or equivalent) on the fittings intended for mooring. For fittings intended to be used for both mooring and towing, TOW, in tonnes, according to 3.6, should be marked in addition to SWL.

4.6.3 The above provisions on SWL apply for the use of no more than one mooring line.

4.6.4 The towing and mooring arrangements plan described in section 5 should define the method of use of mooring lines.

5 Towing and mooring arrangements plan

5.1 The SWL and TOW for the intended use for each shipboard fitting should be noted in the towing and mooring arrangements plan available on board for the guidance of the master. It should be noted that TOW is the load limit for towing purposes and SWL is the load limit for mooring purposes.

5.2 Information provided in the plan should include, in respect of each shipboard fitting:

- .1 location on the ship;
- .2 fitting type;
- .3 SWL/TOW;

- .4 purpose (mooring, normal towing or other towing); and
- .5 method of applying load of towing or mooring line including limiting fleet angle, i.e. angle of change in direction of a line at the fitting.

5.3 Furthermore, information provided on the plan is to include:

- .1 the arrangement of mooring lines showing number of lines (N);
- .2 the ship design minimum breaking load of each mooring line (MBL_{SD});
- .3 the length of each mooring line;
- .4 restrictions or limitations on the type (including material and construction), stiffness and diameter of mooring lines which are compatible with the mooring equipment and fittings; and
- .5 the acceptable environmental conditions as given in appendix A, section 3 for the recommended ship design minimum breaking load of mooring lines for ships with Equipment Number EN > 2000:
 - .1 30 second mean wind speed from any direction (v_W or v_W^* according to 3.1.3 or 3.2.2, respectively); and
 - .2 maximum current speed acting on bow or stern ($\pm 10^\circ$).

Note: When the applied design environmental criteria exceed the above given criteria, information provided in the plan should include the design environmental criteria, similar to the parameters in appendix A:

- .1 wind speed and direction; and
- .2 current speed and direction.

APPENDIX A

MOORING AND TOW LINES

1 General

1.1 The mooring lines for ships with Equipment Number (EN) of less than or equal to 2,000 are given in section 2. For other ships the mooring lines are given in section 3.

1.2 The applicable provisions for tow lines are given in section 2.

1.3 The EN should be calculated in compliance with appendix B. Deck cargo as given by the loading manual should be included for the determination of side-projected area A.

1.4 Sections 2 and 3 specify the minimum recommended number and minimum strength of mooring lines (MBL_{SD}). The designer should consider verifying the adequacy of mooring lines based on assessments carried out for the individual mooring arrangement, expected shore-side mooring facilities and expected prevalent environmental conditions.

2 Mooring lines for ships with $EN \leq 2000$ and tow lines

2.1 The minimum recommended mooring lines for ships having an EN of less than or equal to 2,000 are given in table 1.

2.2 For ships having the ratio $A/EN > 0.9$ the following number of lines should be added to the number of mooring lines as given in table 1:

one line where $0.9 < \frac{A}{EN} \leq 1.1$,

two lines where $1.1 < \frac{A}{EN} \leq 1.2$,

three lines where $1.2 < \frac{A}{EN}$.

2.3 The tow lines are given in table 1 and are intended as own tow line of a ship to be towed by a tug or another ship.

Table 1: Mooring and tow lines for ships with EN ≤ 2000

EQUIPMENT NUMBER		MOORING LINES		TOW LINE*
Exceeding	Not exceeding	No. of mooring lines	Ship design minimum breaking load (kN)	Ship design minimum breaking load (kN)
1	2	3	4	5
50	70	3	37	98
70	90	3	40	98
90	110	3	42	98
110	130	3	48	98
130	150	3	53	98
150	175	3	59	98
175	205	3	64	112
205	240	4	69	129
240	280	4	75	150
280	320	4	80	174
320	360	4	85	207
360	400	4	96	224
400	450	4	107	250
450	500	4	117	277
500	550	4	134	306
550	600	4	143	338
600	660	4	160	370
660	720	4	171	406
720	780	4	187	441
780	840	4	202	479
840	910	4	218	518
910	980	4	235	559
980	1,060	4	250	603
1,060	1,140	4	272	647
1,140	1,220	4	293	691
1,220	1,300	4	309	738
1,300	1,390	4	336	786
1,390	1,480	4	352	836
1,480	1,570	5	352	888
1,570	1,670	5	362	941
1,670	1,790	5	384	1,024
1,790	1,930	5	411	1,109
1,930	2,080	5**	437**	1,168
2,080	2,230	**	**	1,259
2,230	2,380	**	**	1,356
2,380	2,530	**	**	1,453
2,530	-	**	**	1,471

* Information is provided in relation to 3.3.1.2 and 3.4.1.2 of the annex to Revised guidance and provision on board of such a line is not necessary under this guidance.

** For ships with EN > 2,000 see section 3 of appendix A.

3 Mooring lines for ships with EN > 2,000

3.1 General

3.1.1 The following is defined with respect to the purpose of mooring lines (see also figure below):

- .1 *Breast line*: A mooring line that is deployed perpendicular to the ship, restraining the ship in the off-berth direction;
- .2 *Spring line*: A mooring line that is deployed almost parallel to the ship, restraining the ship in fore or aft direction; and
- .3 *Head/Stern line*: A mooring line that is oriented between longitudinal and transverse direction, restraining the ship in the off-berth and in fore or aft direction. The amount of restraint in fore or aft and off-berth direction depends on the line angle relative to these directions.

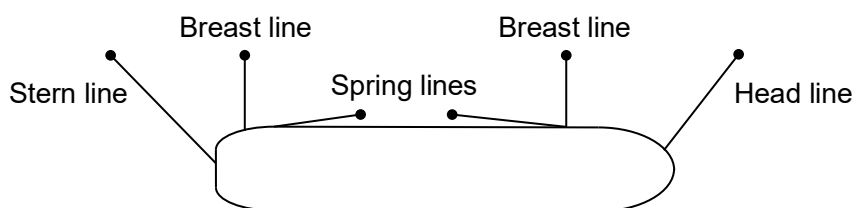

- .4 Breast lines provide the maximum transverse restraint and spring lines the maximum longitudinal restraint against vessel movement in athwart and in fore-aft direction, respectively. Head and stern lines are much less effective for these purposes. The applied mooring layout should follow these principles as far as possible with respect to the port facilities and as far as reasonable with respect to the vertical line angles.

3.1.2 The strength of mooring lines and the number of head, stern and breast lines for ships with an EN > 2,000 are based on the side-projected area A_1 . Side projected area A_1 should be calculated similar to the side-projected area A according to appendix B but considering the following conditions:

- .1 For oil tankers, chemical tankers, bulk carriers and ore carriers the lightest ballast draft should be considered for the calculation of the side-projected area A_1 . For other ships the lightest draft of usual loading conditions should be considered if the ratio of the freeboard in the lightest draft and the full load condition is equal to or above two. Usual loading conditions mean loading conditions as given by the trim and stability booklet that are to be expected to regularly occur during operations, excluding light weight conditions, propeller inspection conditions, etc.
- .2 Wind shielding of the pier can be considered for the calculation of the side-projected area A_1 unless the ship is intended to be regularly moored to jetty-type piers. A height of the pier surface of 3 m above the waterline may be assumed, i.e. the lower part of the side-projected area with a height of 3 m above the waterline for the considered loading condition may be disregarded for the calculation of the side-projected area A_1 .

- .3 Deck cargoes as given by the loading manual should be included for the determination of side-projected area A_1 . Deck cargo may not need to be considered if a usual light draft condition without cargo on deck generates a larger side-projected area A_1 than the full load condition with cargo on deck. The larger of both side-projected areas should be chosen as side-projected area A_1 .

3.1.3 The mooring lines as given hereunder are based on a maximum current speed of 1.0 m/s and the following maximum wind speed v_w , in m/s:

$$\begin{aligned} v_w &= 25.0 - 0.002 (A_1 - 2,000) \text{ for passenger ships, ferries and car carriers} \\ &\quad \text{with } 2,000 \text{ m}^2 < A_1 \leq 4,000 \text{ m}^2 \\ &= 21.0 \text{ for passenger ships, ferries and car carriers with } A_1 > 4,000 \text{ m}^2 \\ &= 25.0 \text{ for other ships} \end{aligned}$$

3.1.4 The wind speed is considered representative of a 30 second mean speed from any direction and at a height of 10 m above the ground. The current speed is considered representative of the maximum current speed acting on bow or stern ($\pm 10^\circ$) and at a depth of one-half of the mean draft. Furthermore, it is considered that ships are moored to solid piers that provide shielding against cross current.

3.1.5 Additional loads caused by, for example, higher wind or current speeds, cross currents, additional wave loads or reduced shielding from non-solid piers may need to be particularly considered. Furthermore, it should be observed that unbeneficial mooring layouts can considerably increase the loads on single mooring lines.

3.2 Ship design minimum breaking load

3.2.1 The ship design minimum breaking load, in kN, of the mooring lines should be taken as:

$$MBL_{SD} = 0.1 \cdot A_1 + 350$$

3.2.2 The ship design minimum breaking load may be limited to 1,275 kN (130 t). However, in this case the moorings are to be considered as not sufficient for environmental conditions given by A.3.1.3. For these ships, the acceptable wind speed v_w^* , in m/s, can be estimated as follows:

$$v_w^* = v_w \cdot \sqrt{\frac{MBL_{SD}^*}{MBL_{SD}}}$$

where v_w is the wind speed as per 3.1.3 above, MBL_{SD}^* the breaking strength of the mooring lines intended to be supplied and MBL_{SD} the breaking strength as recommended according to the above formula. However, the ship design minimum breaking load should not be taken less than corresponding to an acceptable wind speed of 21 m/s:

$$MBL_{SD}^* \geq \left(\frac{21}{v_w}\right)^2 \cdot MBL_{SD}$$

3.2.3 If lines are intended to be supplied for an acceptable wind speed v_w^* higher than v_w as per 3.1.3, the ship design minimum breaking load should be taken as:

$$MBL_{SD}^* = \left(\frac{v_w^*}{v_w}\right)^2 \cdot MBL_{SD}$$

3.3 Number of mooring lines

3.3.1 The total number of head, stern and breast lines should be taken as:

$$n = 8.3 \cdot 10^{-4} \cdot A_1 + 6$$

3.3.2 For oil tankers, chemical tankers, bulk carriers and ore carriers, the total number of head, stern and breast lines should be taken as:

$$n = 8.3 \cdot 10^{-4} \cdot A_1 + 4$$

3.3.3 The total number of head, stern and breast lines should be rounded to the nearest whole number.

3.3.4 The number of head, stern and breast lines may be increased or decreased in conjunction with an adjustment to the strength of the lines. The adjusted strength, MBL_{SD}^{**} , should be taken as:

$$MBL_{SD}^{**} = 1.2 \cdot MBL_{SD} \cdot n/n^{**} \leq MBL_{SD} \quad \text{for increased number of lines,}$$

$$MBL_{SD}^{**} = MBL_{SD} \cdot n/n^{**} \quad \text{for reduced number of lines,}$$

where MBL_{SD} is MBL_{SD} or MBL_{SD}^* specified in 3.2, as appropriate; n^{**} is the increased or decreased total number of head, stern and breast lines and n the number of lines for the considered ship type as calculated according to 3.3.1 or 3.3.2 without rounding.

3.3.5 Vice versa, the strength of head, stern and breast lines may be increased or decreased in conjunction with an adjustment to the number of lines.

3.3.6 The total number of spring lines should be taken not less than:

two lines where $EN < 5,000$; and

four lines where $EN \geq 5,000$.

3.3.7 The strength of spring lines should be the same as that of the head, stern and breast lines. If the number of head, stern and breast lines is increased in conjunction with an adjustment to the strength of the lines, the number of spring lines should be taken as follows, but rounded up to the nearest even number:

$$n_s^* = MBL_{SD} / MBL_{SD}^{**} \cdot n_s$$

where MBL_{SD} is MBL_{SD} or MBL_{SD}^* specified in 3.2, as appropriate, MBL_{SD}^{**} the adjusted strength of lines as specified in 3.3.4, n_s the number of spring lines as given in 3.3.6 and n_s^* the increased number of spring lines.

APPENDIX B

EQUIPMENT NUMBER

The equipment number (EN) should be calculated as follows:

$$EN = \Delta^{2/3} + 2.0hB + \frac{A}{10}$$

where:

Δ = Moulded displacement, in tonnes, to the Summer Load Waterline.

B = Moulded breadth, in metres.

h = Effective height, in metres, from the Summer Load Waterline to the top of the uppermost house; for the lowest tier 'h' should be measured at centreline from the upper deck or from a notional deck line where there is local discontinuity in the upper deck (see figure below for an example).

$$h = a + \sum h_i$$

a = Distance, in metres, from the Summer Load Waterline amidships to the upper deck.

h_i = Height, in metres, on the centreline of each tier of houses having a breadth greater than $B/4$.

A = Side-projected area, in square metres, of the hull, superstructures and houses above the Summer Load Waterline which are within the equipment length of the ship and also have a breadth greater than $B/4$.

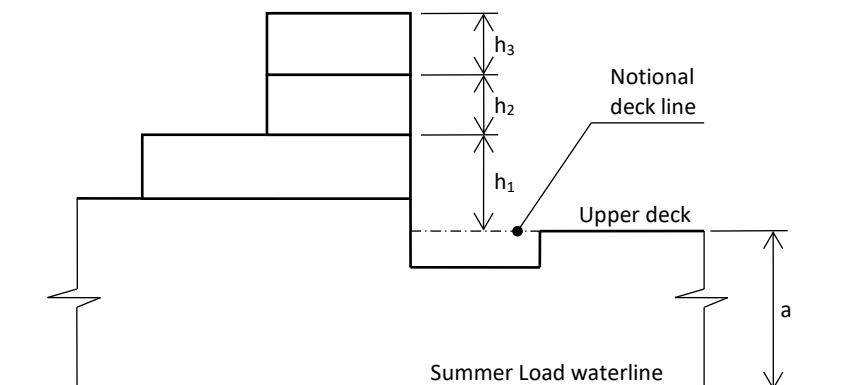

NOTES:

- 1 When calculating h , sheer and trim should be ignored, i.e. h is the sum of freeboard amidships plus the height (at centreline) of each tier of houses having a breadth greater than $B/4$.
- 2 If a house having a breadth greater than $B/4$ is above a house with a breadth of $B/4$ or less, then the wide house should be included but the narrow house ignored.

- 3 Screens or bulwarks 1.5 metres or more in height should be regarded as parts of houses when determining h and A . The height of the hatch coamings and that of any deck cargo, such as containers, may be disregarded when determining h and A . With regard to determining A , when a bulwark is more than 1.5 metres high, the area shown below as A_2 should be included in A .

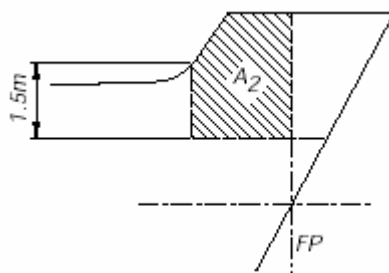

- 4 The equipment length of the ships is the length between perpendiculars but should not be less than 96% nor greater than 97% of the extreme length on the Summer Waterline (measured from the forward end of the waterline).
